



Mayor Tab Townsell

City Attorney Michael Murphy

City Clerk/Treasurer Michael O. Garrett

Aldermen

Ward 1 Position 1 – Andy Hawkins
Ward 1 Position 2 – David Grimes
Ward 2 Position 1 – Mark Vaught
Ward 2 Position 2 – Shelley Mehl
Ward 3 Position 1 – Jack Bell
Ward 3 Position 2 – Mary Smith
Ward 4 Position 1 – Theodore Jones, Jr.
Ward 4 Position 2 – Shelia Whitmore

City of Conway

**5:30pm Committee Meeting
Analysis of Special Revenue Projects**

6:30pm -- Council Meeting
Courtroom in District Court Building
810 Parkway, Conway, AR 72034
March 25th, 2008

1. **Call to Order**
2. **Roll Call**
3. **Minutes:** March 6th, 2008
4. **Recognition of Guests: *Employee Service Awards***
5. **Public Hearings:**

6. Report of Standing Committees:

A. Community Development Committee (Planning, Zoning, Permits, Community Development, Historic District, Streets, & Conway Housing Authority)

1. Consideration of the approval of the reappointment of Ruth Glover to the Board of Housing Authority for an additional five year term.
2. Consideration of the approval of the appointment of William Adkisson to the Conway Corporation Board of Directors.
3. Consideration of entering into an agreement and an ordinance appropriating funding for the Faulkner County Senior Citizens Program & Faulkner County Council of Developmental Disabilities for transportation services.
4. Consideration of a conditional use permit to allow MF-1 density in R-2A for property located at the northwest corner of Monroe Street and Ingram Street with the address of 504 Monroe Street.
5. Ordinance to rezone property located at 1404 Hartje Lane from R-2 to MF-3.
6. Consideration of accepting equipment bids for the Street Department that included a heavy duty skid steer loader, a small skid steer, and a one ton truck (4 door crew cab rear wheel chassis).

B. Public Service Committee (Sanitation, Parks & Recreation, & Physical Plant)

1. Consideration of approving the bid for repairs to the D6R Cat Dozer for the Sanitation Department.

2. Ordinance waving bids for the purchase of biodiesel fuel for the Sanitation Department.
3. Ordinance waiving bids for the purchase of an overhead tube system for the Conway Sanitation scale house.
4. Ordinance amending the fee structure for specific waste items accepted by the Sanitation Department.
5. Consideration of entering into an agreement with UCA and Youth Softball Association of Conway for the rental use of softball fields at UCA.
6. Consideration to enter into an agreement with Carter & Burgess to perform professional design services for the City of Conway for park improvements at the YBMA Baseball Park (the "Park").

C. Public Safety Committee (Police, CEOC, IT Technology, Fire, Dist. Court & City Att., & Animal Control)

1. Ordinance appropriating donated funds to the Conway Police Department.
2. Ordinance appropriating funds for software support for the AS400 for the Finance & Human Resource Office.

D. Personnel

1. Consideration of the reclassification of Street Department positions to the appropriate title and compensation level based on job duties and responsibilities.

7. Old Business

- A. Consideration of rejecting the low bidder Poor Boy's Handyman and accepting the next low bidder for cleanup at 1470 Wildflower Road.

8. New Business

- A. Consideration of nominations to various City Boards and Commissions. *(Information to be provided prior to meeting)*

Adjournment



Housing Authority of the City of Conway

MARYANN BOYD
Executive Director

March 10, 2008

Honorable Mayor Tab Townsell & City Council
City of Conway
1201 Oak Street
Conway, AR 72032

Dear Mayor & City Council Members:

The term of Ruth Glover as a commissioner on the Board of the Housing Authority of the City of Conway, expired on January 15, 2008.

At the Annual Meeting held January 28, 2008, the Board voted to recommend that Ruth Glover be re-appointed for another five year term beginning January 15, 2008. The Board requests the approval of the City of Council as to this appointment.

Sincerely,

A handwritten signature in cursive script that reads "Mary Boyd".

Mary Boyd
Executive Director



Conway
Corporation

6A-2

Operators of the City-owned Electric, Electronic & Water Systems

March 19, 2008

The Honorable Tab Townsell, Mayor
and Members of the City Council
City of Conway, Arkansas
1201 Oak Street
Conway, AR 72032

Dear Ladies and Gentlemen:

The Board of Directors of the Conway Corporation, in conformance with Resolution 88-11, published a legal notice in the Log Cabin Democrat on January 24, 2008, advertising for nominees to the Conway Corporation Board of Directors. (A copy of that legal notice is enclosed.)

As of March 8, 2008, the expiration of the nominating period, ten nominations had been received.

The Conway Corporation Board of Directors met on March 18, 2008, and Mr. William C. (Bill) Adkisson was elected to succeed Mr. Tom Courtway, whose term expires May 8, 2008.

As mandated by the Articles of Incorporation of the Conway Corporation, it is my pleasure to submit to the Conway City Council for its ratification and approval the election of Mr. William C. Adkisson.

We respectfully request your favorable consideration.

Sincerely,

Richard Arnold
Chief Executive Officer
Conway Corporation

RA:na

Enclosure



**City of Conway, Arkansas
Ordinance No. O-08- __**

AN ORDINANCE APPROPRIATING FUNDS FOR SENIOR CITIZENS PROGRAM; AND FOR OTHER PURPOSES.

WHEREAS, there is a need to support the Senior Citizen Transportation Program with funding to the Faulkner County Senior Citizens Program.

WHEREAS, the Faulkner County Senior Citizens Program is requesting a total \$41, 538 for these transportation needs for the calendar year 2008.

NOW THEREFORE, BE IT ORDAINED BY THE CITY COUNCIL OF THE CITY OF CONWAY, ARKANSAS THAT:

SECTION 1. The City of Conway shall appropriate \$41,538 from General Fund – Fund Balance Appropriation Account (01.990) to the Account (01.106.863) for the Senior Citizen Transportation Program.

SECTION 2. All ordinances in conflict herewith are repealed to the extent of the conflict.

PASSED this 25th day of March, 2008.

APPROVED:

Mayor Tab Townsell

ATTEST:

**Michael O. Garrett
City Clerk/Treasurer**

Faulkner County Senior Citizens Program

1620 Donaghey Ave. / P.O. Box 1429
Conway, Arkansas 72033

Telephone (501) 327-2895
Fax (501) 329-0196

December 6, 2007

Mayor Tab Townsell
Conway City Council
City of Conway
1201 Oak St.
Conway, AR 72032

Dear Mayor Townsell and Members of the City Council:

We are extremely appreciative of the funding that the City of Conway provided toward our transportation program in 2007, as are all of the senior citizens that we served. We are currently averaging annual transportation as follows:

Medical Appointments	1,824
Personal Appointments (human service agencies, grocery stores, etc.)	1,788
Return Trips Home	<u>3,612</u>
	7,224

In providing these figures we have isolated only the transportation for which we use city funding. These figures do NOT include transportation to and from our Conway Senior Center or transportation in any of the other 5 communities we serve. At an average cost of \$5.75 we need aggregate funding of \$41,538 in 2008. We have asked for \$24,000 CDBG funding. We would ask that the City of Conway fund the difference between \$41,538 and the amount of CDBG funding for which we are approved (last year it was \$10,000).

As you are aware, we utilize our other transportation funding sources (federal, state, United Way, private grants, donations, and fundraising) to transport our participants to and from centers, and to provide transportation in rural areas. We use city funding specifically to support the transportation we provide elderly citizens on an individual basis within the City of Conway to medical and dental appointments, physical rehabilitation, dialysis, human service agencies, grocery stores, etc. which is by far the most costly yet critical service we provide. Approximately 12% of this transportation involves senior citizens in wheel chairs and who require a vehicle with a wheel chair lift. The service we provide, and that you fund, is what separates Conway from so many other communities, large and small, with regard to being a community that truly cares about, and cares for, its dependent citizens. It takes so little and means so much, and the leaders of this community are to be truly commended for their commitment to those who depend upon them.

Thank you for your consideration and continued support.

Sincerely,

Debra Robinson

Debra Robinson
Executive Director





City of Conway, Arkansas
Ordinance No. O-08- _____

**AN ORDINANCE APPROPRIATING FUNDS FOR FAULKNER COUNTY COUNCIL ON
DEVELOPMENTAL DISABILITIES; AND FOR OTHER PURPOSES.**

WHEREAS, there is a need to support with funding the Faulkner County Council on Developmental Disabilities.

WHEREAS, the Faulkner County Council on Developmental Disabilities is requesting \$30,000 for transportation needs for the calendar year 2008.

**NOW THEREFORE, BE IT ORDAINED BY THE CITY COUNCIL OF THE CITY OF CONWAY,
ARKANSAS THAT:**

SECTION 1. The City of Conway shall appropriate \$35,000 from General Fund – Fund Balance Appropriation Account (01.990) to the Account (01.106.872) for the Faulkner County Council on Development Disabilities.

SECTION 2. All ordinances in conflict herewith are repealed to the extent of the conflict.

PASSED this 25th day of March, 2008

APPROVED:

Mayor Tab Townsell

ATTEST:

Michael O. Garrett
City Clerk/Treasurer

FCC/DD
Faulkner County Council on Developmental Disabilities
P.O. Box 2407
Conway, Arkansas 72033
Phone: 501- 327-3037
Fax: 501-327-8778

Executive Director
Robert D. Wright

Board of Directors
Kathy Hall, President
Roger Williams, Vice Pres.
Jackie Fliss, Sec/Trea.
Tom Erbach
Calvin Price
Dixie Bryson

March 12, 2008

Honorable Mayor Tab Townsell
City of Conway
Conway, Arkansas 72034

RE: Transportation Funding

Dear Mayor Townsell:

In a recent survey conducted by United Way, the citizens of Conway identified the lack of public transportation as their principal concern. For several years, Faulkner County Council on Developmental Disabilities (FCC/DD) has helped meet the transportation needs of the citizens of Conway and the surrounding area. Unfortunately, the increasing costs of providing this service coupled with a decrease in funding is jeopardizing our agency's ability to provide this vital service. More specifically, since 2002 the cost of gas has increased by more than 138% (\$1.30 to \$3.10 per gallon) while our Community Development Block Grant (CDBG) has decreased by almost 30% (\$28,500 to \$20,000). Due to the increase in gas prices along with the increasing cost of maintenance, our agency is projecting funding shortfall of approximately \$35,000. To help offset a portion of this shortfall, FCC/DD is requesting financial support in the amount of \$30,000 to enable us to continue our transportation services.

I am enclosing some information regarding our agency. If further information is needed, please contact me at 1301 North Museum Road or call (501) 327-3037. On behalf of our Board of Directors, I would like to thank you and the City Council for your financial assistance and cooperation in the previous years.

Sincerely Yours,

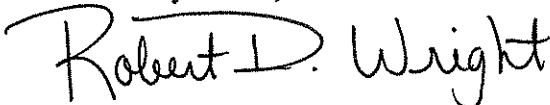

Robert D. Wright

Executive Director, FCC/DD

Summary

When you hire a person with a developmental disability, you get a reliable and dependable worker. You benefit from our support and training of the worker, and you make it possible for your new employee to be gainfully employed, self-supporting, a tax payer and an independent citizen of our community.

We are asking you to join us in our efforts to Provide New Horizons to persons with developmental disabilities by offering "Employment Opportunities."

*Please join us in
providing "New Horizons"!*



United Way of Faulkner County

Faulkner County Council
on Developmental
Disabilities

**SUPPORTED
WORK
PROGRAM**

Providing New
Horizons

1301 N. Museum Road
P. O. Box 2407
Conway, Arkansas 72033
(501) 327-3037
Fax: (501) 327-8778
FCCDD@conwaycorp.net

Robert D. Wright - Executive Director

FAULKNER COUNTY COUNCIL ON DEVELOPMENTAL DISABILITIES SUPPORTED WORK PROGRAM

Mission Statement

The mission of the Faulkner County Council on Developmental Disabilities is to improve the quality of life for people with developmental disabilities.

What is Supported Employment?

Supported Employment is an exciting, innovative approach to employment for persons with developmental disabilities; providing: job development, job placement, on-the-job training and follow along services.

Supported Employment Project Goal

To expand Employment, Social and Economic opportunities for people with disabilities to enhance their overall social and economic standing in the community.

What Services Does FCC/DD Provide:

A. Joint Opportunities Building

Success (JOBS+)
8 Classes (Self Esteem, Why We Work, Applications, Resume, Preparing for the Interview, Interview, What the Employer Expects, Job Retention)

B. Job Development / Job Placement (Jobs developed are reflective of personal interests and abilities as well as employer needs.)

C. Job Coaching (Provides a supportive network to help the worker learn the job and retain the job.)

D. Transportation (FCC/DD provides transportation for the mentally and physically disabled, disadvantaged and elderly citizens of Faulkner County. Services include transportation for employment, medical and personal needs.)

E. Extended Services (Provides follow-up support to employers and the employee.)

FCC/DD

FAULKNER COUNTY COUNCIL ON DEVELOPMENTAL DISABILITIES

“Providing opportunities in training and employment for individuals with developmental disabilities.”

The Faulkner County Council on Developmental Disabilities is a private not-profit agency existing since 1984 located in Conway, Arkansas. FCC/DD initiated a supported employment program in 1987 providing job development, job placement, on-the-job training and follow-along services to assist persons 18 years of age and older who, due to the severity of their disability, are not able to function independently on the job without supports. Arkansas Rehabilitation Services provides eligibility certification to FCC/DD to do job development, job readiness classes and job-coach training. Without long-term support services, retraining, intervention and counseling being provided, these individuals could not maintain continued employment. FCC/DD also provides transportation services. The FCC/DD supported employment project goal is to expand employment, social and economic opportunities for people with disabilities, therefore, enhancing their overall social and economic standing in the community.



Tiffany Stubbs continues to progress at her job at McDonald's.



Tony Nutt recently celebrated 10 years of service at Walmart.

Rosi Wilkinson utilizes FCC/DD transportation services weekly to access vital community resources.



FCC/DD
1301 N. Museum Road
P.O. Box 2407
Conway, Arkansas 72033
(501) 327-3037
FCCDD@conwaycorp.net





CONWAY PLANNING COMMISSION

1201 OAK STREET CONWAY, AR 72032 (501) 450-6105

6A-4

March 18, 2008

Council Members
Conway, AR 72032

Dear Council Members:

A request for a conditional use permit to allow MF-1 density in R-2A for property located at the northwest corner of Monroe Street and Ingram Street with the address 504 Monroe Street and the legal description:

Being the East 37 feet of Lot 24, all of Lots 25 and 26,
Block 4 of Harkrider Addition to the City of Conway,
Arkansas, as shown on Plat of Records in Plat Book A, Page
46, Records of Faulkner County, Arkansas.

was reviewed by the Planning Commission at its regular meeting on March 17, 2008. The Planning Commission voted 6 – 0 that the request be sent to the City Council with a recommendation of approval with the following conditions attached.

1. All residences must be single-family dwellings.
2. No more than three single-family dwellings are allowed.
3. Exterior building materials must be at least 50% brick.
4. Parking shall be a maximum of 6 spaces—two per residence.
5. One 12-foot maximum width driveway for new structure off Monroe Street allowed.

Submitted by,

Junior Storie, Chairman
Planning Commission

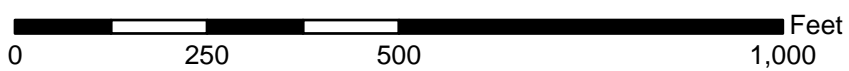
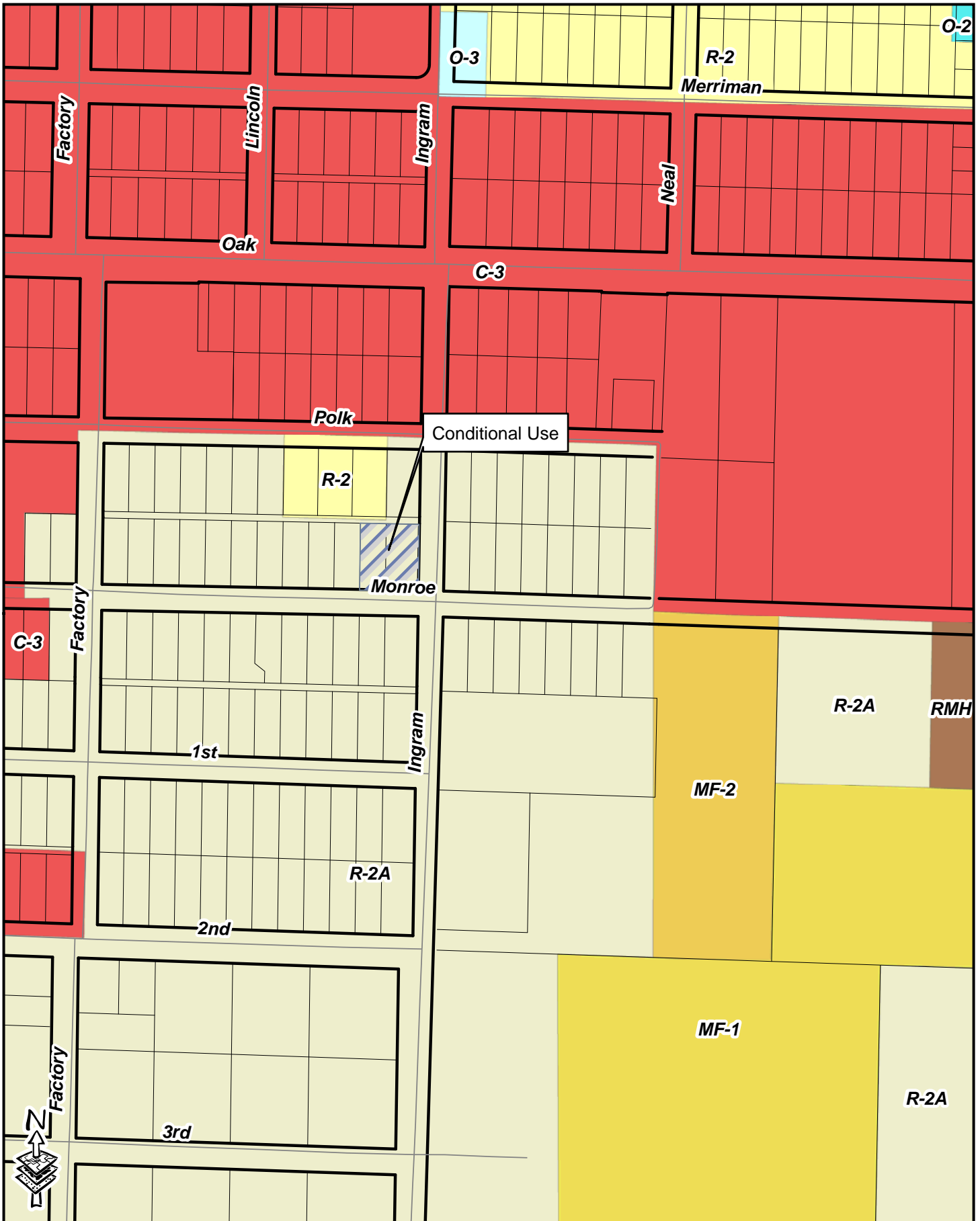

**Hatcher
Conditional Use**



City of Conway, Arkansas
Ordinance No. O-08-_____

AN ORDINANCE AMENDING SECTIONS 201.1 AND 201.3 OF THE CONWAY ZONING ORDINANCE; TO REZONE PROPERTY LOCATED AT 1404 HARTJE LANE FROM R-2 TO MF-3; DECLARING AN EMERGENCY AND FOR OTHER PURPOSES:

NOW, THEREFORE, BE IT ORDAINED BY THE CITY COUNCIL OF THE CITY OF CONWAY, ARKANSAS:

SECTION 1: That the Zoning District Boundary Map of the Conway Land Development Code be amended by changing all the R-2 symbols and indications as shown on the Zoning District Boundary Map in an area described as follows:

Lot 3 of the Bass and DeRosa Replat

to those of MF-3, and a corresponding use district is hereby established in the area above described and said property is hereby rezoned.

SECTION 2: That all ordinances in conflict herewith are repealed to the extent of the conflict.

SECTION 3: That this ordinance is necessary for the protection of the public peace, health and safety and an emergency is hereby declared to exist, and this ordinance shall be in full force and effect from and after its passage and approval.

Passed this 25th day of March, 2008.

Approved:

Mayor Tab Townsell

Attest:

Michael O. Garrett
City Clerk/Treasurer



CONWAY PLANNING COMMISSION

1201 OAK STREET CONWAY, AR 72032 (501) 450-6105

March 18, 2008

Council Members
Conway, AR 72032

Dear Council Members:

A request for rezoning from R-2 to MF-3 for property that is located at 1404 Hartje Lane with the legal description:

Lot 3 of the Bass and DeRosa Replat

was reviewed by the Planning Commission at its regular meeting on March 17, 2008. The Planning Commission voted 6 – 0 that the request be sent to the City Council with a recommendation of approval.

Submitted by,

Junior Storie, Chairman
Planning Commission

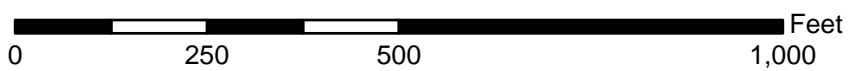
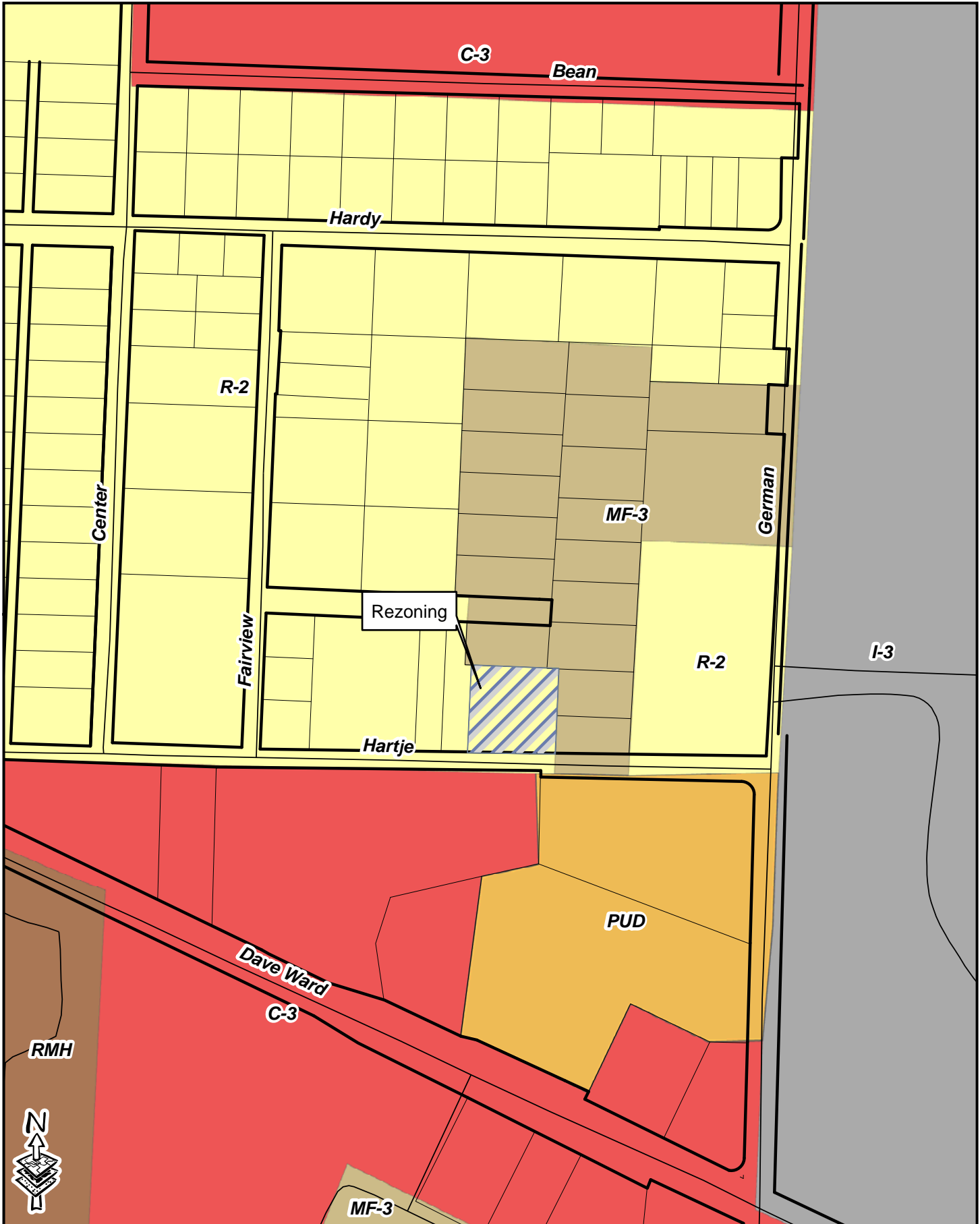

**Derosa Rezone R-2 to MF-3
Rezoning**

MEMORANDUM

TO: MAYOR TAB TOWNSELL
 FROM: RONNIE HALL, P.E.
 DATE: March 18, 2008
 REFERENCE: STREET DEPARTMENT EQUIPMENT BIDS

Bids were received at 10:00 am Tuesday March 18, 2008 for a heavy duty Skid Steer Loader to operate the asphalt pavement grinder, a small skid steer loader for cleaning out concrete drainage channels and a one ton truck for the concrete crew. The results of the bids are as follows:

Heavy Duty Skid Steer Loader (84 min Hp)

AgPro - John Deere 332	\$33,504.95
Hugg & Hall Equipment - Bobcat S-330	\$34,766.00
J.A. Riggs Tractor Co. for a Cat 272C (Does not Meet Specs)	\$33,580.00

The Cat machine will not attach to our pavement grinder

Small Skid Steer Loader (33 min Hp)

Hugg & Hall - Bobcat S-100	\$15,019.00
AgPro - John Deere 313	\$17,588.95
Scott Equipment - Case 420	\$22,586.00

The John Deere 313 and Case 420 exceed the maximum width specified to allow access to narrow concrete channels.

One Ton Truck 4-door Crew Cab dual rear wheel Chassis

Bale Chevrolet - Chevrolet SILVERADO 3500HD, 6.0L V-8, (353 hp) 6 speed Allison transmission	\$22,223.00
Smith Ford - Ford Super Duty F350 5.4L V-8, 5 speed automatic transmission	\$25,897.00

We recommend award of these bids to the low bidders as follows:
 AgPro for the John Deere 332
 Hugg & Hall for the Bob Cat S-330
 Bale Chevrolet for the Chevrolet 3500



CITY OF CONWAY
SANITATION DEPARTMENT

*P.O. Box 915
4550 Hwy. 64 West
Conway, AR 72033
(501) 450-6155
Fax: (501) 450-6157*

Cheryl Harrington
Director

March 13, 2008

Mayor Tab Townsell
City Hall
1201 Oak Street
Conway, AR 72032

Re: Repairs for a D6R Cat Dozer

Dear Mayor Townsell,

Bids were submitted at 10:00 am, Monday February 25, 2008 at Conway City Hall for Repairs on D6R Cat Dozer. One bid were submitted:

Scott Construction Equipment	\$62,654.00
------------------------------	-------------

I recommend the bid from Scott Construction Equipment for \$62,654.00. It was the bid that met or exceeded all specifications that we required.

Please advise if you have questions or need additional information.

Sincerely,

Cheryl Harrington
Sanitation Director

City of Conway – Sanitation Department

Bid Number: 2008-24

Bid Opening Date: February 25th, 2008

Total Cost for Repairs

\$ 62,654.⁰⁰

Unsigned bids will be rejected:

Authorized Agent Bidding on this project:

Scott Construction Equipment

Company Name

Ray Lambert

Company Representative Name

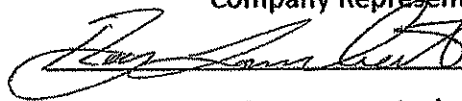

Representative's Signature

10923 West I.30

Address

Email Address

Little Rock AR

72209

City

State

Zip

501-941-4552

501-455-3046

Telephone Number

Fax Number

2-25-08

Date

Please feel free to submit additional information on this bid on a separate piece of paper; however this sheet has to be included & signed with any bid submitted.



**City of Conway, Arkansas
Ordinance No. O-08-_____**

**AN ORDINANCE WAIVING BIDS FOR SOLE SOURCE VENDOR FOR BIODIESEL FUEL TO THE
CONWAY SANITATION DEPARTMENT, AND FOR OTHER PURPOSES:**

WHEREAS, the Conway Sanitation Department requests a revenue appropriation of \$32,141 to replace petroleum diesel; and

WHEREAS, Satterfield Oil was awarded the 2008 for all City of Conway gas/diesel needs and the Sanitation Department would like to use biodiesel in all equipment & garbage trucks and purchase such fuel from Satterfield Oil;

NOW THEREFORE BE IT ORDAINED BY THE CITY COUNCIL OF THE CITY OF CONWAY, ARKANSAS THAT:

SECTION 1. The City of Conway shall appropriate \$32,141 from the Sanitation Enterprise Fund Balance Account (50.990) to Sanitation Enterprise Other Equipment (50.118.921) and shall purchase biodiesel fuel from Satterfield Oil.

SECTION 2. All ordinances in conflict herewith are repealed to the extent of the conflict.

PASSED this 25th day of March, 2008.

Approved:

Mayor Tab Townsell

Attest:

Michael O. Garrett
City Clerk/Treasurer



City of Conway, Arkansas
Ordinance No. O-08- _____

AN ORDINANCE WAIVING BIDS FOR THE PURCHASE OF AN OVERHEAD TUBE SYSTEM FOR THE CONWAY SANITATION SCALEHOUSE; AND FOR OTHER PURPOSES

WHEREAS, the City of Conway would like to purchase an overhead tube system to improve customer convenience and employee efficiency; and

WHEREAS, Diebold, Inc. is a sole vendor for the overhead tube system.

WHEREAS, Nabholz Construction has been recommended by Diebold for the construction of the overhead tube system.

NOW, THEREFORE, BE IT ORDAINED BY THE CITY COUNCIL OF THE CITY OF CONWAY, ARKANSAS THAT:

SECTION 1. The City of Conway shall waive the requirement for obtaining bids to purchase the overhead tube system from Diebold as a sole source vendor.

SECTION 2. The City of Conway shall waive the requirement for obtaining bids for construction of the overhead tube system by Nabholz Construction.

SECTION 3. The City of Conway shall appropriate in amount not to exceed \$35,000 from the Sanitation Enterprise Fund Balance Appropriation account (50.990) into the Sanitation Improvement account (50.118.915).

SECTION 4. All ordinances in conflict herewith are repealed to the extent of the conflict.

PASSED this 25th day of March, 2008.

APPROVED:

 Mayor Tab Townsell

ATTEST:

 Michael O. Garrett
 City Clerk/Treasurer



CITY OF CONWAY
SANITATION DEPARTMENT

*P.O. Box 915
4550 Hwy. 64 West
Conway, AR 72033
(501) 450-6155
Fax: (501) 450-6157*

Cheryl Harrington
Director

March 17, 2008

Mayor Tab Townsell
City Council Members

Re: Overhead Tube System

Please find attached a proposal from Diebold, Inc. to install an overhead tube system for the Conway Sanitation Department scalehouse. We have been undergoing repairs and upgrades to the scalehouse and would like to continue by placing a tube system for the employees in the booth as well as for the convenience of our customers.

This system is used by the banks and Diebold, Inc. is a sole source vendor for this product. Nabholz construction is the vendor Diebold, Inc. uses for their site work.

The employees at this time have to deal with dirt, flies and the awning being torn by customers pulling too close to the building. We have purchased new touch screen computers and would like to try to eliminate as much dust and dirt as possible. At this time, the employees use litter pickers to reach the customer.

I am requesting Diebold be used as a sole source vendor to install the tubes for the scale house. An ordinance is attached for Council consideration.

If additional information is needed, please let me know.

Sincerely,

Cheryl Harrington

Cheryl Harrington
Director

Rebecca McHughes

From: Redding, Calvin [calvin.redding@diebold.com]
Sent: Thursday, March 13, 2008 10:56 AM
To: Rebecca McHughes
Subject: Proposal

Here is the proposal for the new drive-in equipment for the Sanitation Department. I will send you some product information on a separate email.

<<is031008.doc>>

Calvin Redding
Senior Sales Representative
DIEBOLD, Inc.
Cell Phone: 501-626-3751
Office Phone: 501-219-3006
Fax: 501-219-3028



PROPOSAL

CITY OF CONWAY
SANITATION DEPARTMENT

Two Diebold VAT 21, 4 ½” overhead tube systems with two customer units and two teller units

One standard tube package for two lanes of VAT 21

Diebold 816 sound system for two teller stations

Delivery and installation of new equipment

TOTAL INVESTMENT.....\$17,465.00

OPTIONAL EQUIPMENT (Additional investment required):

Two wireless audio headset kits with batteries, battery charger and three wearing style kits (Ear hook, neck band, head band)

Additional Investment.....\$1,225.00

Price assumes normal work hour installation, 8 a.m. to 5 p.m., Monday through Friday, and standard Diebold colors. Delivery and installation included. Tax is not included.

Price does not include structural or other modifications to building or property or electrical power for equipment. All openings for equipment and power for equipment to be provided by others per Diebold specifications.

Price is good for thirty (30) days from date of proposal.

Submitted by: Calvin Redding
March 10, 2008

This proposal is based upon your acceptance of the provisions of one of the following signed agreements:

Your signed Diebold Comprehensive Agreement (“DCA”) on file with Diebold.

Diebold’s Offer of Sale Terms of Diebold’s Memorandum of Agreement. Please go to Diebold’s Web site at <http://www.diebold.com/tc> for a copy of the Terms & Conditions.

Your Master Agreement on file with Diebold.

Rebecca McHughes

From: Redding, Calvin [calvin.redding@diebold.com]
Sent: Thursday, March 13, 2008 11:01 AM
To: Rebecca McHughes
Subject: Emailing: 1781752.pdf



1781752.pdf (825
KB)

<<1781752.pdf>> Here is some info on the VAT 21 overhead system. This is the most reliable overhead tube system on the market. First State Bank in Conway uses this as does most of the financial institutions in the area.

Let me know if you need any additional information.
thank you.

Calvin Redding
Senior Sales Representative
DIEBOLD, Inc.
Cell Phone: 501-626-3751
Office Phone: 501-219-3006
Fax: 501-219-3028

The message is ready to be sent with the following file or link attachments:

1781752.pdf

Note: To protect against computer viruses, e-mail programs may prevent sending or receiving certain types of file attachments. Check your e-mail security settings to determine how attachments are handled.

CALL 1-800-999-3600

#134-85 OPERATOR UNIT DETAILS

NOTE:
 MAXIMUM TUBE LENGTH 152 METERS
 (500 LINEAR FEET)

DIMENSIONS IN MILLIMETRES
 (DIMENSIONS IN FEET-INCHES)

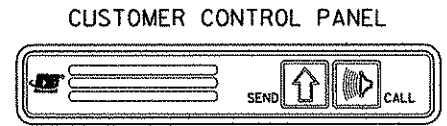
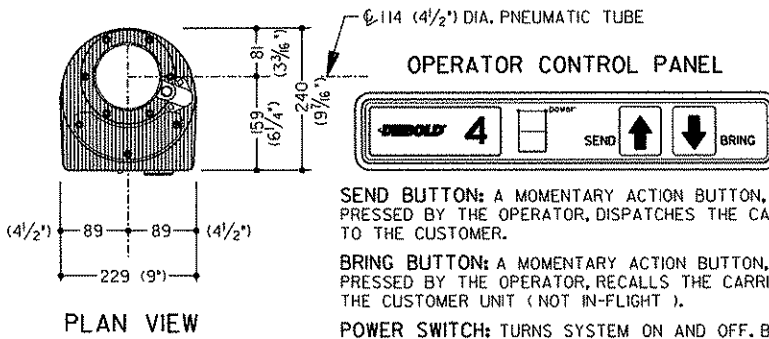

SEND BUTTON: A MOMENTARY ACTION BUTTON, WHEN PRESSED BY THE OPERATOR, DISPATCHES THE CARRIER TO THE CUSTOMER.

SEND BUTTON: A MOMENTARY ACTION BUTTON, WHEN PRESSED BY THE CUSTOMER, DISPATCHES THE CARRIER TO THE OPERATOR.

BRING BUTTON: A MOMENTARY ACTION BUTTON, WHEN PRESSED BY THE OPERATOR, RECALLS THE CARRIER FROM THE CUSTOMER UNIT (NOT IN-FLIGHT).

CALL BUTTON: A MOMENTARY ACTION BUTTON, WHEN PRESSED BY THE CUSTOMER, ACTIVATES THE AUDIO CHIME, INDICATING COMMUNICATION IS DESIRED.

POWER SWITCH: TURNS SYSTEM ON AND OFF. BEFORE SYSTEM IS TURNED OFF CARRIER MUST BE RETURNED TO OPERATOR UNIT AND OPERATOR DOOR MUST BE OPEN.

TYPICAL TRANSACTION

CUSTOMER ARRIVES AT THE CUSTOMER UNIT, WITH THE DOOR OPEN AND THE CARRIER PRESENT. CUSTOMER PLACES TRANSACTION INSIDE CARRIER, AND PASSES SEND BUTTON. BLOWERS ENERGIZE AND THE CARRIER IS DISPATCHED TO THE OPERATOR. UPON ARRIVAL AT THE OPERATOR, THE OPERATOR TERMINAL DOOR WILL OPEN AND THE CUSTOMER UNIT DOOR WILL CLOSE.

WHEN THE OPERATOR COMPLETES THE TRANSACTION, THE CARRIER IS PLACED IN THE OPERATOR TERMINAL, AND THE SEND BUTTON IS PRESSED. BLOWERS ENERGIZE, AND THE CARRIER IS DISPATCHED TO THE CUSTOMER. AFTER THE CARRIER ARRIVES IN THE CUSTOMER UNIT, THE CUSTOMER UNIT DOOR WILL OPEN, AND THE OPERATOR UNIT DOOR WILL CLOSE.

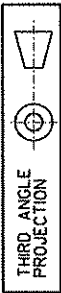

PLAN VIEW

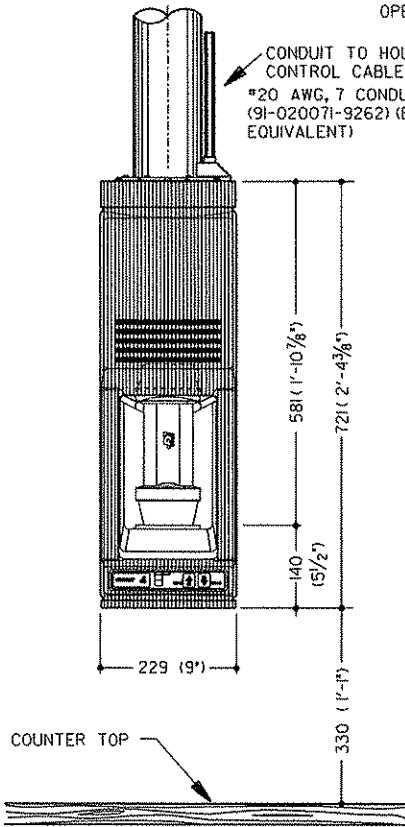

FRONT VIEW

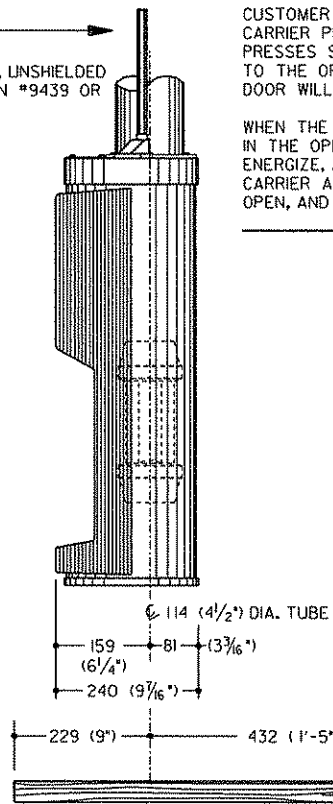

SIDE VIEW

ALTERNATE OPERATOR UNIT INSTALLATION

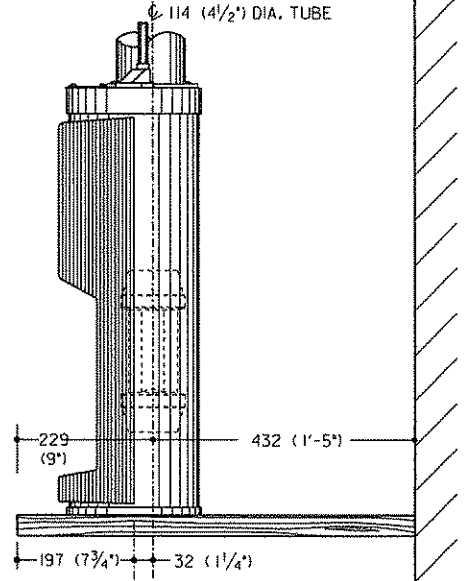

SIDE VIEW

PAGE 1 OF 5

ALL DIMENSIONS AND DESIGN CRITERIA SUBJECT TO CHANGE WITHOUT NOTICE

MULTIPLE UNIT CONFIGURATION

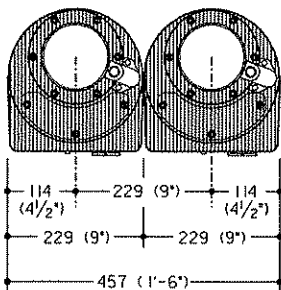

PLAN VIEW
 (2) UNITS

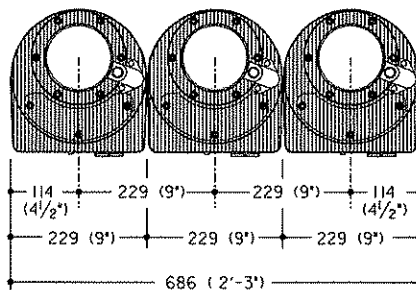

PLAN VIEW
 (3) UNITS

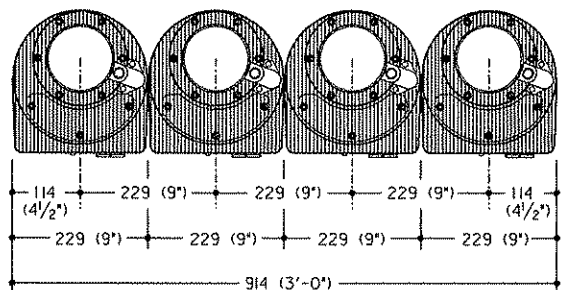

PLAN VIEW
 (4) UNITS

FILE NO. 178-1752 REV. 7



#134-86 CUSTOMER UNIT DETAILS

DIMENSIONS IN MILLIMETRES
(DIMENSIONS IN FEET-INCHES)

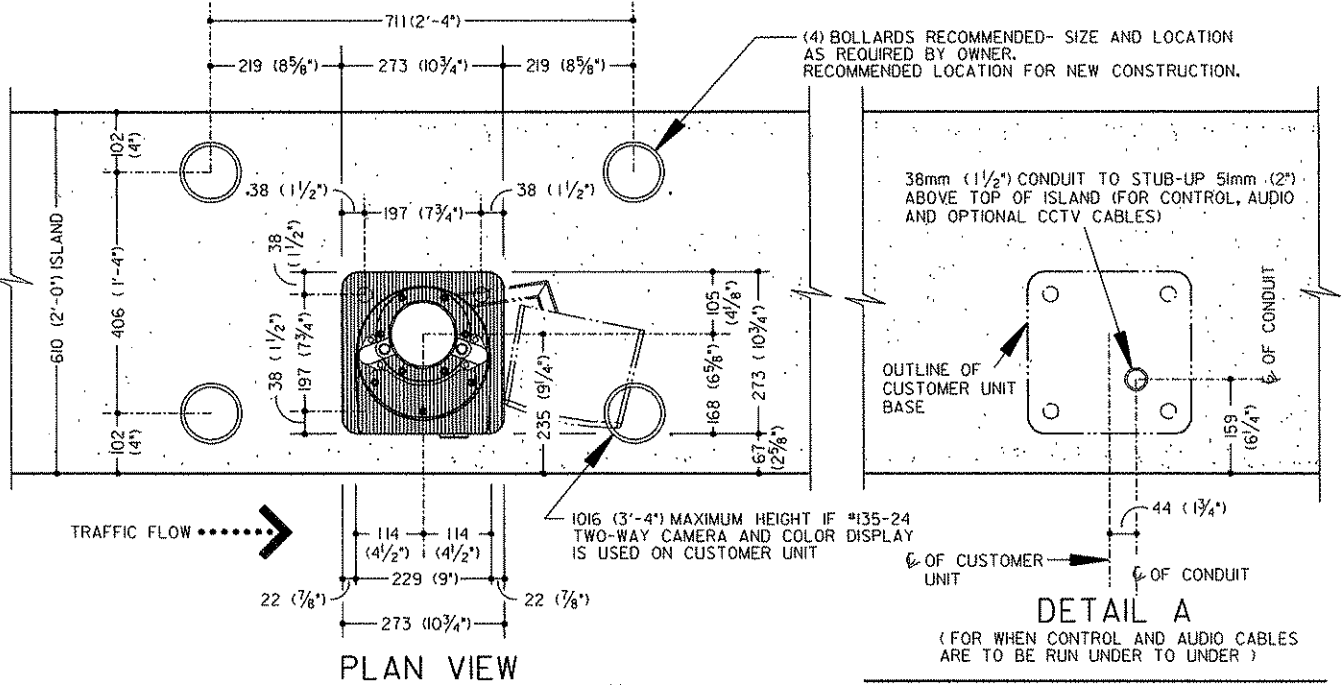

PLAN VIEW

13mm (1/2") DIA. CONDUIT TO HOUSE CONTROL AND AUDIO CABLES

CONTROL CABLE
#20 AWG, 7 CONDUCTOR, UNSHIELDED (19-020071-9262) (BELDEN #9439 OR EQUIVALENT)

AUDIO CABLE
#20 AWG, 6 CONDUCTOR, 3 TWISTED PAIR, INDIV. FOIL SHIELD WITH DRAIN, COLOR CODED (BELDEN #9873 OR EQUIVALENT)

13mm (1/2") DIA. CONDUIT TO HOUSE OPTIONAL CCTV CABLES
SEE VAT 21 TYPICAL SCHEMATIC USING TWO WAY CCTV SYSTEM FILE NUMBER 178-1899

IDENTIFICATION PANEL - NUMBER AND COLOR CODED TO MATCH OPERATOR UNIT

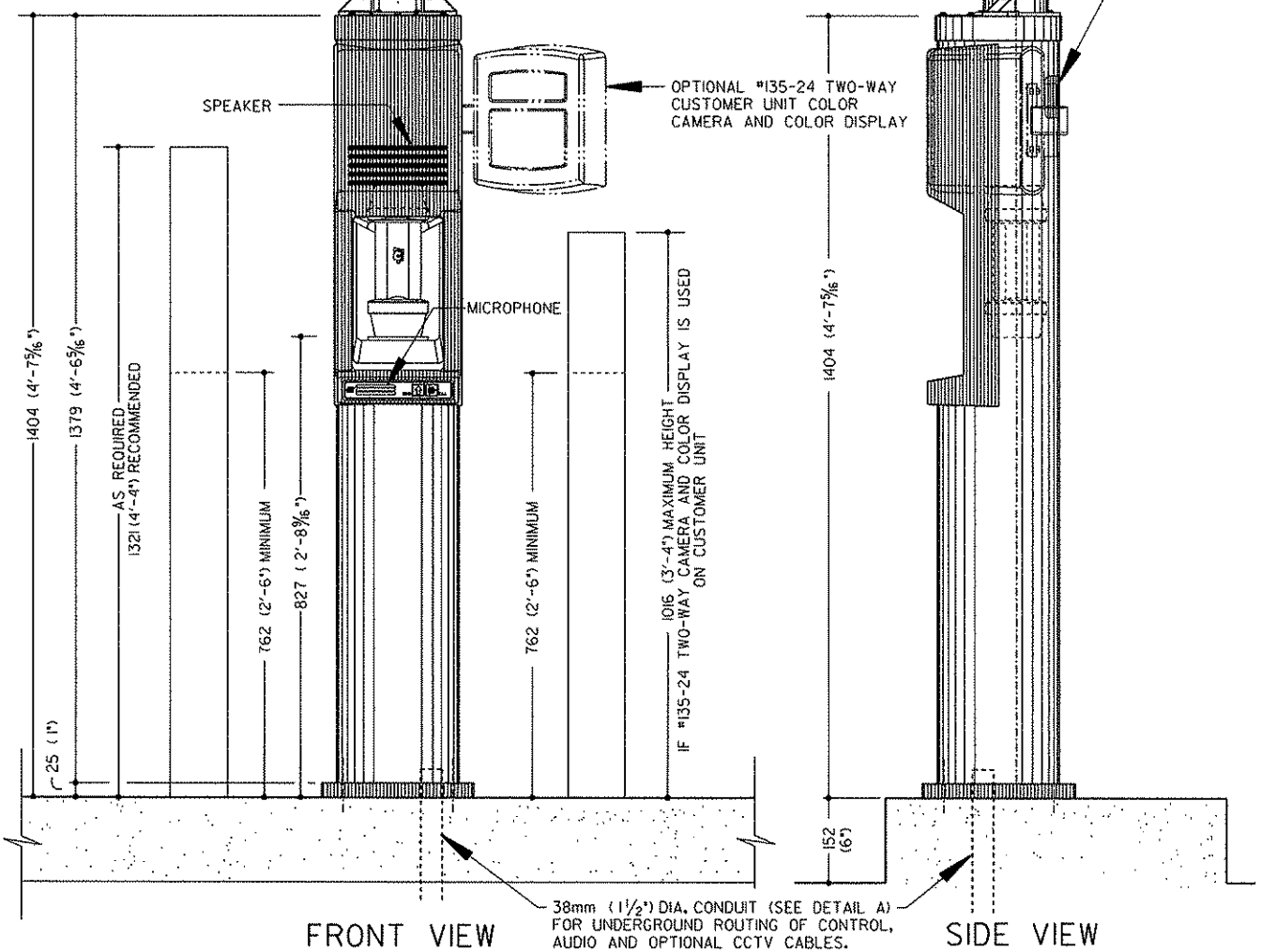

CALL 1-800-999-3600

NOTES:

1. LOCATION AND SIZE OF WALL OPENING MAY VARY WITH TUBE RUN ANGLE BETWEEN OPERATOR AND CUSTOMER UNIT.
2. UNISTRUT SUPPORT BRACKET (BY DIEBOLD)
3. DIMENSION FOR LOCATING TRANSACTION DRAWER MAY VARY WITH UNDERCOUNTER EQUIPMENT ARRANGEMENT. IF POSSIBLE DIMENSION SHOULD BE FIGURED WITH UNDERCOUNTER EQUIPMENT AND TRANSACTION DRAWER CENTERED ON WINDOW.
4. ALL WORK AND MATERIALS SHALL CONFORM TO THE NATIONAL, ALL STATE, AND LOCAL ELECTRICAL CODES WHICH MAY BE APPLICABLE. ELECTRICAL CONTRACTOR TO BE RESPONSIBLE FOR ANY CHANGES NECESSARY TO COMPLY WITH THESE CODES.
5. ALL CONDUIT, POWER WIRES, JUNCTION BOXES, AND OVERLOAD PROTECTION DEVICES, ARE TO BE PROVIDED AND INSTALLED BY THE ELECTRICAL CONTRACTOR.
6. SEE CUT SHEET FILE NUMBER 178-1953 FOR POWER CONSOLIDATION AND DISTRIBUTION GUIDELINES.

DIMENSIONS IN MILLIMETRES
(DIMENSIONS IN FEET-INCHES)



PAGE 3 OF 5

ALL DIMENSIONS AND DESIGN CRITERIA
SUBJECT TO CHANGE WITHOUT NOTICE.

FILE NO. 178-1752 REV. 7

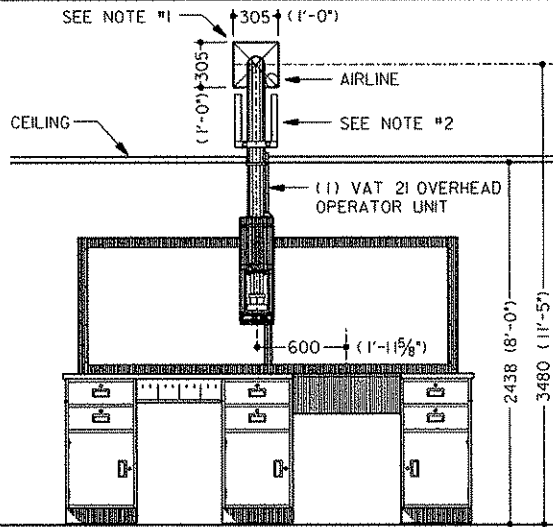

VAT CONFIGURATION 12C-8

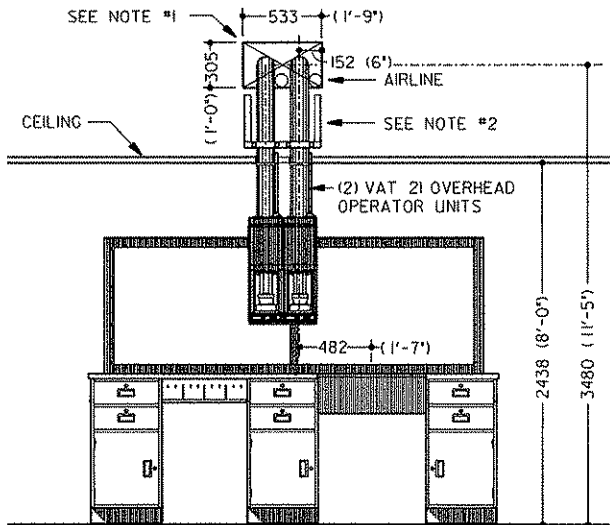

VAT CONFIGURATION 22C-8

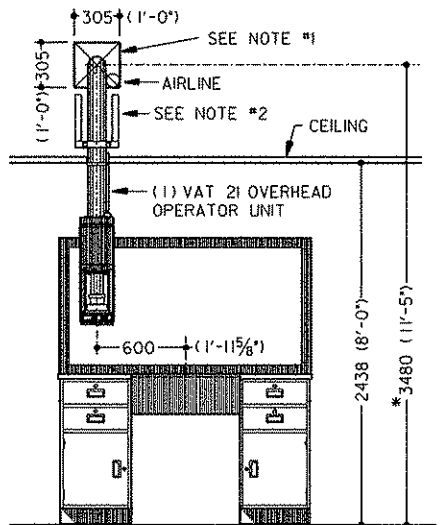

VAT CONFIGURATION 11C

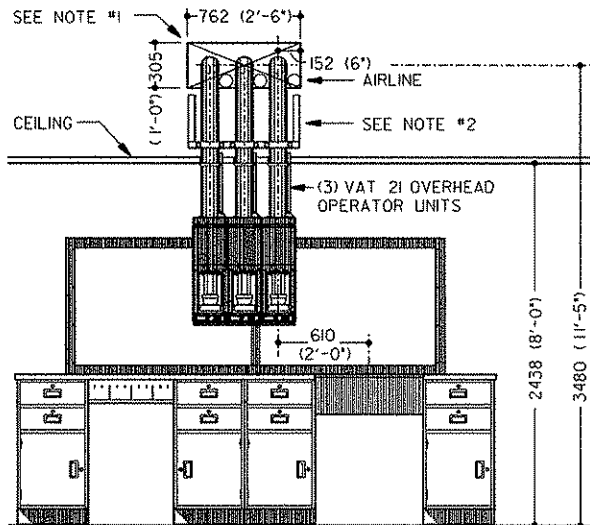

VAT CONFIGURATION 32C-8



DIMENSIONS IN MILLIMETRES
(DIMENSIONS IN FEET-INCHES)



THIRD ANGLE
PROJECTION

ALL DIMENSIONS AND DESIGN CRITERIA
SUBJECT TO CHANGE WITHOUT NOTICE.

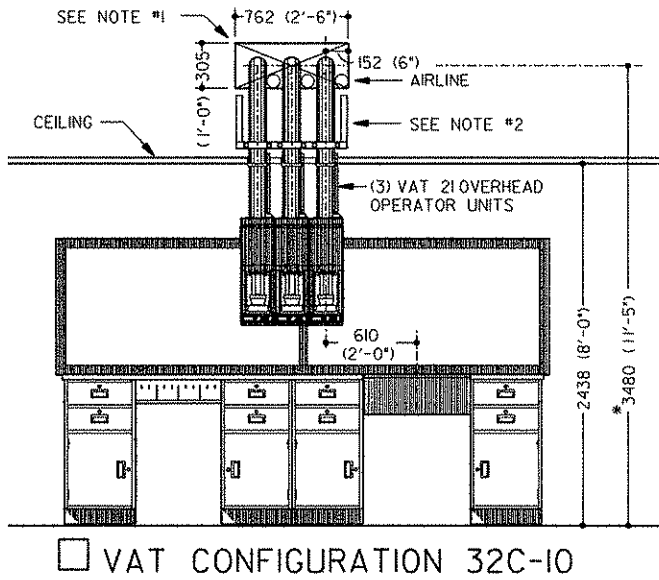
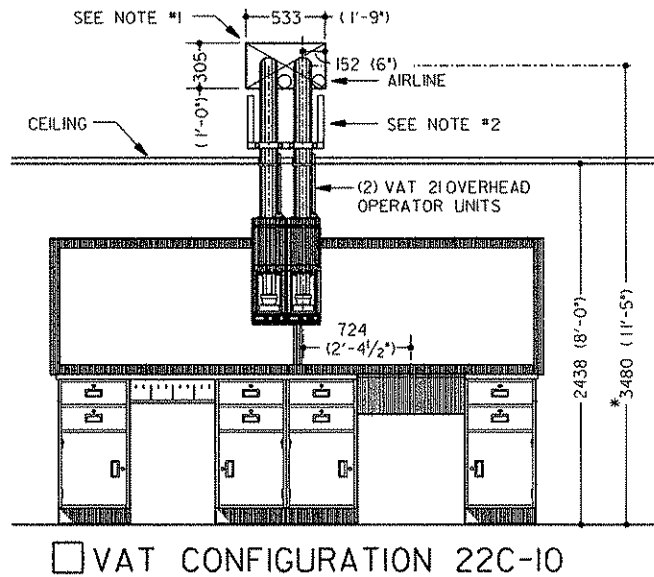
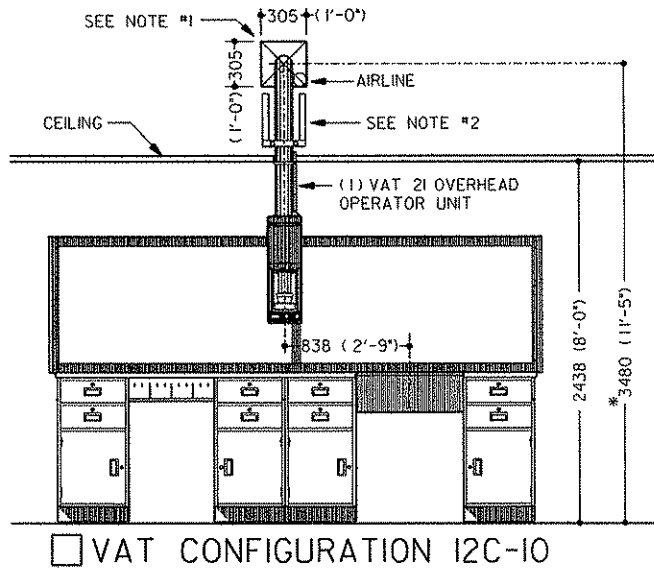



* ALL DIMENSIONS MARKED WITH AN ASTERISK MAY VARY WITH BUILDING/CANOPY CONSTRUCTION

DIMENSIONS IN MILLIMETRES
(DIMENSIONS IN FEET-INCHES)



PAGE 5 OF 5

ALL DIMENSIONS AND DESIGN CRITERIA
SUBJECT TO CHANGE WITHOUT NOTICE.

FILE NO. 176-1752 REV. 7

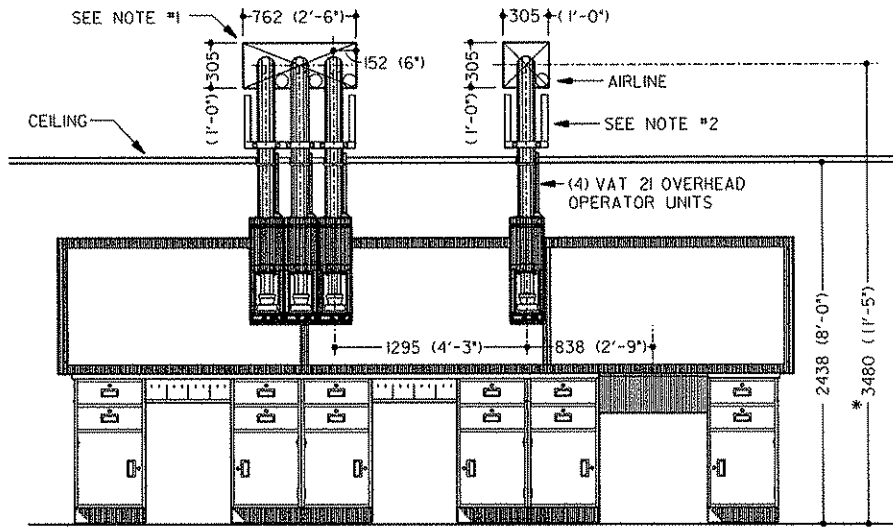

VAT CONFIGURATION 43C-1

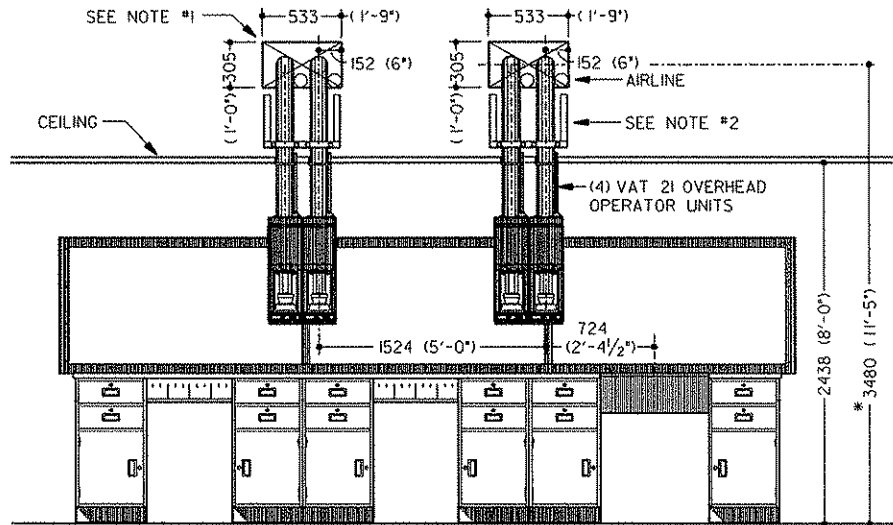

VAT CONFIGURATION 43C-2

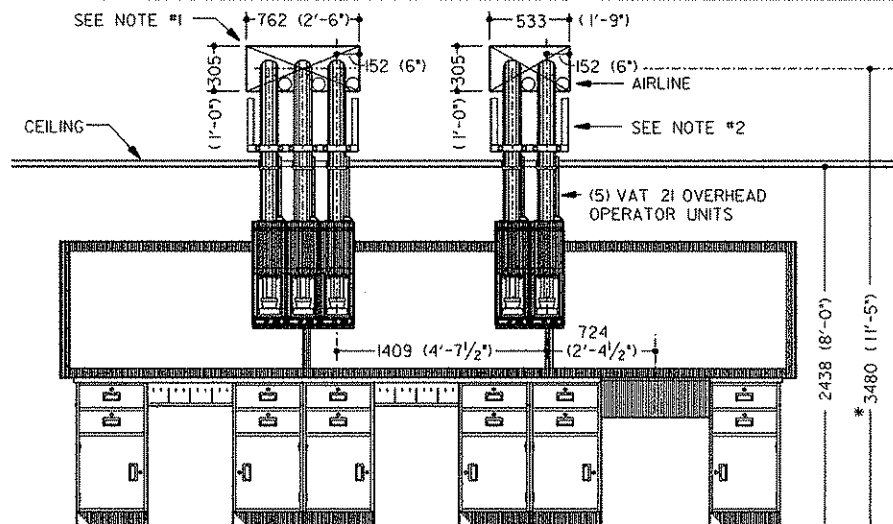

VAT CONFIGURATION 53C



Lump Sum Proposal / Agreement

Proposal For:

City of Conway
Rebecca McHughes
City of Conway

Project Information:

Project Title: Vat 21 Installation/2 Lanes
Location: City of Conway Sanitation, Conway AR
Proposal Number: 030708
Owner Project Number:
Proposal Date: Friday, March 14, 2008

Nabholz Client Service is pleased to submit this Proposal / Agreement for the above referenced project. This proposal is good for 30 days. Should this proposal be acceptable, please sign, date and fax (or return) a copy back to Nabholz Client Service. Thank you for the opportunity to be of service.

SCOPE OF WORK is based on our site visit and as clarified below. Nabholz Client Service shall furnish all labor, materials and equipment unless otherwise noted, for the following specific scope of work:

1. Travel to Diebold to Verify Equipment Availability and Load.
2. Remove portion of Sheet Rock Ceiling to locate HVAC Duct.
3. Modify HVAC Duct to Accommodate Proposed VAT 21 System.
4. Penetrate Roof to install 2 Vat 21 Teller units.
5. Penetrate Façade for Tube Access.
6. Install 2 Diebold Provided Vat 21 Operator Units. (Location Pre Determined by the City of Conway).
7. Install 2 Diebold provided Vat 21 Customer Units. (Location Pre Determined by the City of Conway).
8. Pull Diebold Provided Communication and Control Wire.
9. Install Diebold Provided 816 Audio.
10. Provide Electrical modifications to accommodate proposed Vat 21 and 816 Audio.
11. Provide and Install Steel Bracing to Accommodate VAt 21 System.
12. Install Metal Sheeting to cover Bracing. (Sheeting Color will be as close a match to canvas façade as possible).
13. Install 4x4 Square Tubing for Bracing support and pipe bollards. (Square Tubing will serve as Pipe Bollards as well as support).
14. Fabricate and install one Doghouse or Protection cover for Vat 21 Blower Units.
15. Install DEKTITE roof sealers around each roof Penetration.
16. Repair, Tape and Float Sheet Rock ceiling penetrations.
17. Install Fur Downs to conceal exposed interior Vents.
18. Paint ceiling and Fur Downs.
19. Test units for proper working order.
20. Remove All Nabholz Client Service Debris from job site.

NOTE: This project will commence at close on a Friday Evening and continue through immediate Sunday. Some finish work could be necessary the following Monday or Friday Evening.

SCHEDULE for the above scope of work, is based on normal Nabholz Client Service working hours and days, shall not exceed **10** working days from the project start date. Upon receipt of your written acceptance of this proposal and receipt of applicable permits and governmental approvals, up to **15** working days shall be required as lead time to the project start date. This schedule excludes delays to due to circumstances beyond the control of Nabholz Client Service, such as weather and access to work areas.

EXCLUSIONS from the scope of work in this proposal are as follows:

1. Any City, State or Federal Permits, Fees or Approvals
2. Any Security for this Project
3. Providing of Any Wire



- 4. Any New Electrical Services or Panels
- 5. Any Repair or Replacement of Fabric Façade cover
- 6. Any Millwork Modifications or Additions
- 7. Any concrete Additions or Modifications
- 8. Any Structural Modifications or repairs other than roof Penetrations
- 9. Any Interior Painting other than Ceiling
- 10. Any Exterior Painting

NOTE: Before the signing of this proposal a meeting between, Diebold, The City of Conway and Nabholz Client Services must held so that all parties are in agreement of scope of work.

PAYMENT TERMS for this proposal shall be based on monthly progress invoices, no retainage withheld, submitted by Nabholz Client Service with payments due in full no later than 15 days from the invoice date.

LUMP SUM PRICE OF THIS PROPOSAL \$10,925.00



Agreement

Agreement For:
Diebold, Inc.

Project Information: City of Conway
Project Title: Sanitation Dept. Vat 21

Contract Documents: this Agreement, together with the Proposal, shall constitute the Contract Documents and shall govern the rights of the parties hereto. In the event of any inconsistencies this Agreement shall control.

Scope of the Work: shall be per the Contract Documents and shall constitute the "Work". Nabholz Client Service shall use its best care, skill and diligence in supervising and directing the Work; and have responsibility and control over the performance of the Work, including construction methods, techniques, manner and sequences for coordinating and completing the various portions of the Work. Owner expressly warrants that any plans, drawings and specifications furnished by the Owner are true, correct and complete; and Nabholz Client Service is entitled to rely upon the adequacy, accuracy and completeness of such documents. Nabholz Client Service will not be responsible for consequential damages of any type under any circumstances. Unless otherwise noted in the Proposal, Nabholz Client Service excludes performance and payment bonds; rock excavation; asbestos or any other hazardous material removal, disposal, or encapsulation; services of licensed professionals such as attorneys, architects or engineers; costs for the after hour work, shift work or weekend work.

Payment: Owner agrees to pay Nabholz Client Service for the performance of the Work, subject to modification by written change orders signed by both parties. Payments are due and unpaid shall bear interest at the maximum lawful rate. Final Payment shall be due when the Work is completed and final invoice is submitted.

Insurance: Nabholz Client Service shall maintain insurance for Workers Compensation, Builders Risk, Employer's Liability, Comprehensive Automobile Liability, Comprehensive or Commercial General Liability on an occurrence basis.

Disputes: if a dispute arises out of or relates to this Agreement, or the breach thereof, the parties shall attempt to settle the dispute first through direct discussions, then by mediations before recourse to arbitration (unless parties mutually agree otherwise, mediation shall be conducted in accordance with the Construction Mediation Rules of the American Arbitration Association). Disputes shall be decided by arbitration in accordance with the Construction Industry Arbitration Rules of the American Arbitration Association then in effect. The location of the arbitration shall be the location of the Project or Nabholz Client Service at Nabholz Client Service's discretion.

Termination: Owner and Nabholz Client Service may terminate this Agreement only in the event of a material breach and only after providing written notice by letter delivered to the address stated herein and only after more than ten days has elapsed after such written notice without attempts to cure the default.

Exclusion of Warranties: Nabholz Client Service makes no warranties, either express or implied. The implied warranties of MERCHANTABILITY and FITNESS FOR A PARTICULAR PURPOSE are hereby disclaimed.

Miscellaneous: this Agreement is severable, and any part deemed unenforceable shall not render the remaining part unenforceable. All covenants of the Agreement shall be subject to all federal and state laws, executive orders, rules, or regulations, and this Agreement shall not be terminated, in whole or in part, nor the parties held liable in damages, for failure to comply therewith, if compliance is prevented by, or if such failure is the result of any such law, order, rule, or regulation or acts of God. All implied covenants are waived. This Agreement is intended to be the final expression of the parties, and there are no other written or oral agreements relating to the subject thereof. This Agreement may only be amended by a further written agreement signed by both parties. This Proposal/Agreement, when signed by both parties, constitutes the entire agreement and contract between the parties for the performance of the Work described in this Proposal. Faxes of signed Proposal/Agreement are acceptable.

Respectfully Submitted:

Darrell Horton
Project Manager
Nabholz Client Service

Accepted by Owner:

Signature/Title: _____

Acceptance Date: _____



**City of Conway, Arkansas
Ordinance No. O-08-_____**

**AN ORDINANCE AMENDING THE FEE STRUCTURE FOR SPECIFIC WASTE ITEMS ACCEPTED BY THE
SANITATION DEPARTMENT; REQUIRING THAT LOOSE WASTE IS PROPERLY CONTAINED FOR
COLLECTION AND FOR OTHER PURPOSES:**

WHEREAS, the City Council wishes to encourage citizens of Conway to recycle waste material and reduce the quantity of trash which is deposited into the City landfill in order to maximize the revenue generated through the sale of recyclables and to prolong the life of the landfill; and

WHEREAS, the City Council wishes to encourage and reward sound waste management practices in the disposal of electronic waste and white goods by reducing the fee structure for such items; and

WHEREAS, loose trash items can create a littering problem by blowing out of the receptacle when it is emptied into the Sanitation truck if it is not properly contained;

**NOW THEREFORE BE IT ORDAINED BY THE CITY COUNCIL OF THE CITY OF CONWAY, ARKANSAS
THAT:**

SECTION 1. The City of Conway shall implement changes to the fee structure charged to customers obtaining an additional waste cart (green cart) and changes to the fee structure charged to customers for disposal of white goods and electronic waste as per the attached schedule of fees

SECTION 2. The City of Conway shall require all loose waste material to be property bagged or boxed in such a fashion to facilitate the collection of materials without items being disburshed by blowing wind. This requirement applies to all trash items collected in both the green and blue waste receptacles. Violation of such requirement will result in one warning notice given by Sanitation personnel. After one notice is given to a resident, subsequent violations will be referred to the City of Conway Code Enforcement personnel and the resident will be subject to being fined for littering.

SECTION 3. The effective date for the above items shall be the effective date of this ordinance.

SECTION 4. All ordinances in conflict herewith are repealed to the extent of the conflict.

PASSED this 25th day of March, 2008.

APPROVED:

Mayor Tab Townsell

ATTEST:

**Michael O. Garrett
City Clerk/Treasurer**

WHITE GOOD AND ELECTRONIC WASTE DISPOSAL FEE STRUCTURE

Per Item Charge	Collected from Residents Residing in:			
	Conway		Faulkner County	
Refrigerator, Freezer, Air Conditioner, Washer, Dryer, Stove	\$	10.00	\$	15.00
Furnace, Water Heater, Lawn Mower, String Trimmer	\$	5.00	\$	6.00
Riding Mower	\$	10.00	\$	12.00
Computer, small home printer	\$	5.00	\$	7.50
Peripheral, UPS Power supply cord, Portable Television, VCR, DVD, Home Stereo Equipment	\$	2.00	\$	4.50
Console Television	\$	10.00	\$	12.50
Copier, large office printer	\$	25.00 to	\$	25.00 to
	\$	100.00	\$	100.00

FEE STRUCTURE CHARGED FOR ADDITIONAL CART

Customers residing within the City who request an additional green waste cart will be charged a one time, nonrefundable fee of \$50.00 to obtain the cart. The current monthly charge for those customers who have two (2) carts is \$27.93, including sales tax, regardless of whether the second cart is utilized or not. These charges are subject to change by action of the City Council of the City of Conway.

AGREEMENT
between
University of Central Arkansas
and
City of Conway, Arkansas
for
Rental use of the Jefferson D. Farris Jr. Softball Fields
for
2008

Period of Use:

1. The Jefferson D. Farris Jr. Softball Fields number 1,2, and 3 (hereafter "fields") may be used by the City of Conway, Arkansas (hereafter "City") beginning April 28 through July 11, 2008.
2. On or about March 15 each year the City will inform the University of Central Arkansas (hereafter "University") through the Intramural Sports and Recreation Department in writing regarding their intended period of usage of the fields for that year.
3. The fields will be available for the City Monday through Friday. Weekend days (Saturday and Sunday) may be reserved through the University Calendar Office.
4. Either party may cancel this agreement upon written notice to the other party; provided however, the University must notify the City of its intent to cancel the agreement by November 1 of each year if the fields will not be available for the next year.

Terms of Agreement:

1. During the period of use the City will maintain the fields within a standard set by the University and the City. The City will:
 - A. Mow the grass on and around the fields a minimum of once each week. The areas and height to be mowed will be determined by the University.
 - B. Trim (weed eat) in and around the fields, including but not limited to the area around fences and sidewalks and in areas not reachable by mowers.
 - C. Clean the area in and around the fields, including but not limited to parking lots, fields, areas surrounding the fields, bathrooms, concession area, bleachers, and dugouts.
 - D. Water fields and areas around fields in accordance with University standards. Maintain and repair irrigation system on and around fields.
 - E. Maintain dirt infields by 1) drag daily; 2) contain weed and grass growth; and 3) repair areas damaged by usage.
 - F. Any chemicals or fertilizers added to the grass (in addition to normal standards) on or around the fields must be approved by the University prior to application.

AGREEMENT (page #2)

- G. Any field conditioner added to the infield must be approved by the University prior to application.
 - H. Repair any and all damage to the fields or areas surrounding the fields.
 - I. Replace any field lights that go out during usage.
 - J. City will not allow 'soft toss' hitting into the chain link fence around the fields.
- 2. The City will supply all field marking equipment and supplies.
 - 3. The City will contact and work with ARAMARK with regard to concessions during the period of usage.
 - 4. Security.
 - A. The University Police Department (UCAPD) will be notified of City usage of softball fields at least (2) weeks prior to usage.
 - B. Should the service of UCAPD be required, necessary or otherwise requested, prior permission must be obtained during this period of time. A fee may be assessed for these services.
 - 5. The City will uphold State regulations and University policy of facility usage by non-student groups.
 - 6. The City will carry liability insurance naming the University in the policy rider as an additional insured and will provide the University with a copy of the certificate.
 - 7. The University will provide:
 - A. Bases and pitcher plates.
 - B. Irrigation parts and supplies.
 - C. Storage area for City supplies to maintain fields.
 - 8. No rights or obligations under this agreement may be assigned or transferred without the written consent of all parties.

Rental Fee:

- 1. The City will not pay a rental fee to the University, but will:
 - A. Maintain the fields and surrounding area as stipulated in "Terms of Agreement".
 - B. Provide for the cost of all water and electric charges from Conway Corporation during the period of use by the City.

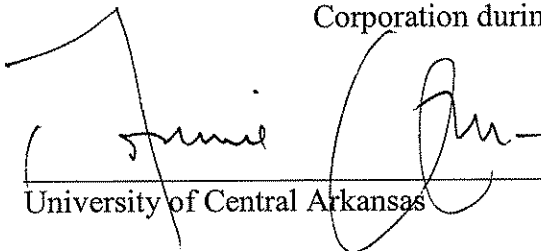

University of Central Arkansas

3-13-08

Date

Mayor, City of Conway

Date

March 10, 2008

Mr. David St. John
President, Youth Softball Association of Conway

Dear Mr. St. John:

The following is intended as an agreement between the University of Central Arkansas (UCA) and the Youth Softball Association of Conway (YSAC). This agreement stipulates that the Department of Intramural Sports and Recreation at UCA will maintain the Farris Field Softball Fields (fields #1, #2, #3, and surrounding grounds) during the period of use by YSAC. Period of use by YSAC is from April 28, 2006 through July 11, 2008. Maintenance of the Farris Fields by the Department of Intramural Sports and Recreation will be conducted to fulfill the agreement between the City of Conway and the University of Central Arkansas.

Staff Costs:

- | | | |
|----|--|----------------|
| 1. | 1.5 staff @ \$6.25 per hour | |
| 2. | One (1) staff - \$6.25 per hour X 8 hours per day | \$50.00 |
| 3. | One half (½) staff - \$6.25 per hour X 4 hours per day | <u>\$25.00</u> |
| 4. | Total staff cost per day | \$75.00 |

Other Cost:

1. In accordance with agreement between City of Conway and UCA the YSAC will bear the cost of:
 - A. Field marking supplies
 - B. Replacement of field lights
 - C. Repair and/or replacement due to damage to fields or surrounding areas
 - D. Garbage pick-up (dumpster) by City at \$40.00 per week

UCA will submit to YSAC an invoice for each month use. Monthly costs may be effected by weather. YSAC will remit to UCA the total staff and other costs for maintenance of the Farris Fields within 10 days after YSAC period of usage.

Youth Softball Association of Conway

Date

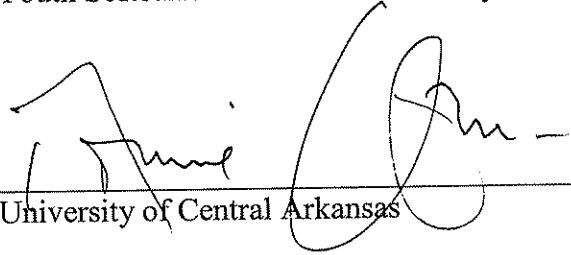

University of Central Arkansas

Date

3-13-08

AGREEMENT
between
University of Central Arkansas
and
City of Conway, Arkansas
and
Youth Softball Association of Conway
for
Rental use of the Jefferson D. Farris Jr. Softball Fields
at the University of Central Arkansas
for
2008

Period of Use:

1. The Jefferson D. Farris Jr. Softball Fields number 1,2, and 3 (hereafter "fields") may be used by the Youth Softball Association of Conway (hereafter "Y.S.A.C") beginning April 28 through July 11, 2008.
2. On or about March 15 each year Y.S.A.C. will inform the City of Conway, Arkansas (hereafter "City") in writing regarding their intended period of usage of the fields for that year.
3. The fields will be available for Y.S.A.C. Monday, Tuesday, Thursday and Friday. Weekend days (Saturday and Sunday) may be reserved through the University Calendar Office.
4. Either party may cancel this agreement upon written notice to the other party; provided however, the City must notify Y.S.A.C. of its intent to cancel the agreement by November 1 of each year if the fields will not be available for the next year.

Terms of Agreement:

1. During the period of use Y.S.A.C. will maintain the fields within a standard set by the University and the City. The Y.S.A.C. will:
 - A. Mow the grass on and around the fields a minimum of once each week. The areas and height to be mowed will be determined by the University.
 - B. Trim (weed eat) in and around the fields, including but not limited to the area around fences and sidewalks and in areas not reachable by mowers.
 - C. Clean the area in and around the fields, including but not limited to parking lots, fields, areas surrounding the fields, bathrooms, concession area, bleachers, and dugouts.
 - D. Water fields and areas around fields in accordance with University standards. Maintain and repair irrigation system on and around fields.
 - E. Maintain dirt infields by 1) drag daily; 2) contain weed and grass growth; and 3) repair areas damaged by usage.
 - F. Any chemicals or fertilizers added to the grass (in addition to normal standards) on or around the fields must be approved by the University prior to application.

- G. Any field conditioner added to the infield must be approved by the University prior to application.
 - H. Repair any and all damage to the fields or areas surrounding the fields.
 - I. Replace any field lights that go out during usage.
 - J. Y.S.A.C. will not allow 'soft toss' hitting into the chain link fence around the fields.
2. The Y.S.A.C. will supply all field marking equipment and supplies.
 3. The Y.S.A.C. will contact and work with ARAMARK with regard to concessions during the period of usage.
 4. Security.
 - A. The University Police Department (UCAPD) will be notified of Y.S.A.C. usage of softball fields at least (2) weeks prior to usage.
 - B. Should the service of UCAPD be required, necessary or otherwise requested, prior permission must be obtained during this period of time. A fee may be assessed YSAC for these services.
 5. The Y.S.A.C. will uphold State regulations and University policy of facility usage by non-student groups.
 6. The Y.S.A.C. will carry liability insurance naming the University in the policy rider as an additional insured and will provide the University with a copy of the certificate.
 7. The University will provide:
 - A. Bases and pitcher plates.
 - B. Irrigation parts and supplies.
 - C. Storage area for Y.S.A.C. supplies to maintain fields.

Rental Fee:

1. The Y.S.A.C. will not pay a rental fee to the City, but will:
 - A. Maintain the fields and surrounding area as stipulated in "Terms of Agreement".
 - B. The City will provide for the cost of all water and electric charges from Conway Corporation during the period of use by the Y.S.A.C..

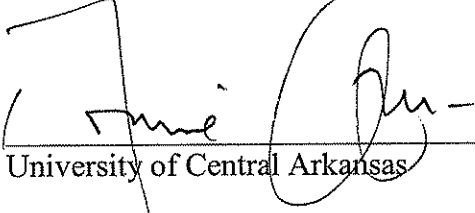

 University of Central Arkansas

3-13-08

 Date

 Mayor, City of Conway

 Date

 Youth Softball Association of Conway

 Date



10816 Executive Center,
Suite 300
Little Rock, AR 72211-4383
Phone: 501.223.0515
Fax: 501.223.2470
www.c-b.com

**AGREEMENT FOR PROFESSIONAL SERVICES
FOR
YBMA BASEBALL PARK
Conway, Arkansas**

March 18, 2008

I. PROJECT DESCRIPTION

Carter & Burgess, Inc. ("C&B") will perform professional design services for the City of Conway ("the City") for park improvements at the YBMA Baseball Park (the "Park"). This work will be guided by the "YBMA Baseball Park Master Plan", previously developed by C&B and dated June, 2007. C&B will prepare final construction documents for the park improvements for the purpose of bidding the work in accordance with City standards and budgets, as well as federal, state and local laws.

C&B's scope of work includes professional landscape architectural, architectural and engineering design services. The program for the Park improvements will be based on the Master Plan Preliminary Budget Projections as identified by the City and C&B dated August 1, 2007. This scope of work and fee schedule is based upon an approved program and approximate construction budget of \$10,183,000.75 as identified by the City on August 1, 2007.

II. SCOPE OF SERVICES

A. BASE MAP PREPARATION & FINAL PROGRAM DEVELOPMENT

1. C&B will utilize the existing survey information as currently being prepared by C&B, for the YBMA Baseball Park and the current site conditions. The City will also provide C&B any additional information required to perform this Scope of Services for on-site and off-site conditions including, but not limited to: above and below ground utilities; easements; property lines; subdivision layouts, roadways, vegetation, hydrology information, etc. Based upon the existing survey and additional information provided by the City, C&B will prepare an existing conditions base map(s) for use in Design Development and final Construction Documents. Should any additional site survey information be necessary, the City will be responsible for providing the information.
2. During the base map preparation, C&B will meet with the City staff to discuss the Park development program and specifically define the City's needs. This meeting will also confirm the final budget allocation by the City for the construction of the Park improvements.

B. PRELIMINARY DESIGN CONCEPT

1. C&B will prepare a Preliminary Design Concept Plan for the proposed Park improvements. The Concept will be based upon the City approved program items, and the Phase I construction budget of \$10,183,278.75. The Preliminary Design Concept Plan will also be based upon the "YBMA Baseball Park Master Plan" as previously prepared by C&B and approved by the City.
2. Based upon the Preliminary Design Concept Plan, C&B will prepare a Preliminary Cost Estimate for the proposed improvements.
3. C&B will attend one (1) meeting with the City to review the Preliminary Design Concept Plan and Cost Estimate to confirm the overall design and obtain City approval before proceeding into the Design Development phase of work. If the City increases the program and construction budget, C&B will review with the City the required additional fees necessary to cover the increase in scope of work. C&B will not proceed into the Design Development phase until the final program, cost estimates, and consultant design fees have been approved in writing by both C&B and the City.

C. DESIGN DEVELOPMENT

1. Based upon approval of the Preliminary Design Concept plan from the City, C&B will prepare Design Development drawings for the proposed Park improvements. The Design Development drawings will be prepared at an approximate 50% level of completion of Construction Documents.
2. The City will provide to C&B all front end documents, contracts, insurance requirements, general conditions, etc. for use by C&B in preparing the specifications and contract documents.
3. C&B will prepare a preliminary Table of Contents for the specifications and contract documents.
4. C&B will submit the Design Development drawings and Table of Contents for the specifications and contract documents to the City for review and approval.
5. The City will forward, in writing, to C&B all review comments for the Design Development drawings submittal. C&B will obtain these comments and approval from the City prior to proceeding into the final construction documents.

D. FINAL CONSTRUCTION DOCUMENTS

1. Based upon approval from the City for the Design Development drawings submittal, C&B will prepare final Construction Documents at an approximate 95% level of completion. The Construction Documents will be comprised of both the drawings and the specifications and contract documents.
2. Based upon the 95% Construction Documents, C&B will prepare a final cost estimate for all the proposed Park improvements.

3. C&B will submit the 95% Construction Documents and cost estimate to the City for final review and comments. The City will provide C&B final, written comments for all revisions requested to the Final Construction Documents.
4. Based upon the final written comments received from the City, C&B will prepare final 100% Construction Documents for the City to utilize in bidding the project.

E. BID PHASE

1. C&B will attend a pre-bid meeting with City representatives and the Construction Manager (“the CM”).
2. C&B will assist the City in preparing addendum(s), if required, during the bid phase.
3. C&B will assist the City in reviewing the CM’s bid and providing a recommendation to the City for award of contract.

F. STORM WATER POLLUTION PREVENTION PLAN (SWPPP)

1. In conjunction with the completion of the Final Construction Documents, C&B will prepare a Storm Water Pollution Prevention Plan (SWPPP) for the proposed site. Any other environmental engineering services would be considered additional services.

G. CONSTRUCTION ADMINISTRATION

1. C&B will assist the City by attending a maximum of twelve (12) 2-hour progress meetings during construction to evaluate completion of work by the Contractor. Should the number of required meetings or amount of meeting time increase, such time can be provided by C&B as an additional service as requested and approved by the City in writing. The City will be responsible for the day-to-day administration of the construction contract.
2. C&B will prepare a written Field Report for each meeting attended during the construction of the project.
3. C&B will process submittal and shop drawing reviews as submitted by the CM during the construction process. Pay applications will also be reviewed each month by C&B and will then be forwarded to the City with the appropriate recommendation.
4. C&B will assist the City in attending one (1) final project walk-through with the CM and his subcontractors to review the completion of work. C&B will provide written comments to the City for the City to utilize in preparing a final “punch list” for work to be completed by the CM.
5. C&B will provide as-builts to the owner as prepared by the contractor. C&B will scan hard copies of the contractor’s as-built mark ups if electronic files are required by the city. C&B will not provide CAD drawings of the as-builts.

III. BASIS OF COMPENSATION

The cost for performing these services set forth herein are based upon an approximate construction budget of \$10,183,278.75 and will be as follows:

A.	Base Map Preparation & Final Program Development (Lump Sum).....	\$ 24,642
B.	Preliminary Design Concept (Lump Sum).....	\$ 57,471
C.	Design Development (Lump Sum).....	..\$290,159
D.	Final Construction Documents (Lump Sum).....	..\$387,370
E.	Bid Phase (Lump Sum).....	\$ 7,547
F.	Construction Administration (Lump Sum).....	\$ 30,778
	Total Basic Design Services.....	\$797,967
G.	Storm Water Pollution Prevention Plan (SWPPP) (Lump Sum).....	\$ 4,000
H.	Reimbursable Expenses	\$ 12,695
	Total Design and Reimbursable Fee	\$814,662

Reimbursable Expenses: These expenses included, but may not be limited to such items as: will reproduction costs, computer plotting, printing, mileage, fax, xerox copies, photography, meals, travel, lodging, rental car, couriers, deliveries, etc.

IV. ADDITIONAL SERVICES

Additional Services, not included in this Scope of Services, will be negotiated with the City as necessary. Compensation will be based upon either a mutually agreed lump sum fee or on an hourly basis. See Attachment "A", Billing Rate Schedule, for hourly rates. Items which would be considered Additional Services could include: site surveying, geotechnical investigation, design of additional program items beyond what has been identified by the City for the Park improvements, alternate bid items, additional meetings with City Staff and/or presentation to other groups, additional site visits during construction activity, etc.

VI. ASSUMPTIONS

- A. The City has designated a construction budget of approximately \$10,183,278.75 for the Park Should this construction budget increase or decrease, or the City should require alternate bid items be included in the construction document package, C&B and the City staff will re-evaluate this scope of work and determine the basis of compensation in accordance with revisions to the design services.

- B. The City will provide as expeditiously as possible all base information, that it currently has in its possession, necessary to complete the Scope of Services described herein. This Scope of Services does not include any survey work. Should additional survey information be needed by C&B, the City will provide this information to C&B. ALL INFORMATION PROVIDED BY THE CITY IS ASSUMED TO BE ACCURATE AND COMPLETE, unless indicated otherwise by the City. Any information required to complete this Scope of Services that cannot be readily provided by the City will remain the responsibility of the City. All such information shall be provided to C&B and any costs associated with acquisition of information will be borne by the City.
- C. This Scope of Services does not include any hydraulic or hydrology engineering design services for the existing creek or other water permitting related issues, such as the following: Federal Emergency Management Agency (FEMA) map revision preparation and processing; U.S. Army Corps of Engineers 404 permitting, ADEQ permits or applications. Any services such as these would be considered additional services.
- D. Any services for environmental engineering such as an Environmental Assessment (E.A.) or Environmental Impact Statement (E.I.S.) are not included in this Scope of Services and would be considered additional services.
- E. The City will pay for all required governmental processing fees and public notice advertising costs.
- F. It is anticipated that the park design will be prepared as one bid package. If additional bid packages are required by City for phasing breakouts, C&B will re-evaluate the scope of services to address additional fees not covered in this scope of work.

VII. COST ESTIMATES

Any cost estimates provided by C&B will be on a basis of experience and judgement, but since it has no control over market conditions or bidding procedures, C&B cannot warrant that bids or ultimate construction costs will not vary from these cost estimates; however, C&B acknowledges that the City is relying on the cost estimates provided by C&B and expects minimal variation from the cost estimates provided.



**City of Conway, Arkansas
Ordinance No. O-08-___**

AN ORDINANCE APPROPRIATING DONATED FUNDS TO THE CONWAY POLICE DEPARTMENT; AND FOR OTHER PURPOSES

WHEREAS, the Conway Police Department has been donated \$1475.14 from Fred’s Dollar Store;

WHEREAS, the Conway Police Department has been donated \$1500.00 from First State Bank;

WHEREAS, the Conway Police Department has been paid \$50.00 for restitution from the District Court of Faulkner County;

WHEREAS, the Conway Police Department has been paid \$200.00 for restitution from the Faulkner Circuit Court.

NOW, THEREFORE, BE IT ORDAINED BY THE CITY COUNCIL OF THE CITY OF CONWAY, ARKANSAS THAT:

SECTION 1. The City of Conway shall accept the Fred’s donation and appropriate them to the Police Department’s Crime Prevention account (01.113.737)

Section 2. The City of Conway shall accept the donation from First State Bank and restitution funds and appropriate to the Police Department’s Uniform account (01.113.292)

SECTION 3. All ordinances in conflict herewith are repealed to the extent of the conflict.

PASSED this 25th day of March, 2008.

APPROVED:

Mayor Tab Townsell

ATTEST:

**Michael O. Garrett
City Clerk/Treasurer**



**City of Conway, Arkansas
Ordinance No. O-08-_____**

AN ORDINANCE APPROPRIATING FUNDS FOR SOFTWARE SUPPORT FOR THE AS 400; AND FOR OTHER PURPOSES.

WHEREAS, the City of Conway has an immediate need to pay for annual software support for the AS400 software packages to be used by the Finance & Human Resource Department; and

WHEREAS, this was not previously budgeted or appropriated by Council action;

NOW THEREFORE, BE IT ORDAINED BY THE CITY COUNCIL OF THE CITY OF CONWAY, ARKANSAS THAT:

SECTION 1. The City of Conway shall appropriate an amount not to exceed \$17,000.00 as a General Fund Balance (01.990) appropriation for the payment of software support (01.112.270).

SECTION 2. All ordinances in conflict herewith are repealed to the extent of the conflict.

PASSED this 25th day of March, 2008.

APPROVED:

Mayor Tab Townsell

ATTEST:

**Michael O. Garrett
City Clerk/Treasurer**

	Service Proposal
X	Reclassification

City of Conway Service Proposal & Reclassification Request

Attach your back-up to this form when submitting Service Proposals and Reclassification Requests to the Budget Office.

Department / Division Name	201 / Conway Street Department
-----------------------------------	--------------------------------

	Position Title	Pay Grade	Annual Salary
Proposed:	Maintenance Specialist I	9	15,754.00
Current:	Part Time Construction Aide/Mower	Part Time	14,506.00

"Current" information needed for reclassification only

Estimated Cost of Position:

Expenses:	
Salary Cost (when reclass, calculate the difference between current & proposed only)	1,248.00
Benefits (FICA-Medicare & Non-Uniform Pension Only)	3,638.00
Total	4,886.00

Salary and benefit costs are based on the costs for 19 pay periods - 1520 hours

Estimated Operating Expenses: Account Number / Name	Amount
Total Operating Expenses	-

Estimated Capital Expenses: Account Number / Name	Amount
Total Capital Expenses	-

Total Estimated Cost of New Position	
---	--

	Service Proposal
X	Reclassification

City of Conway Service Proposal & Reclassification Request

Attach your back-up to this form when submitting Service Proposals and Reclassification Requests to the Budget Office.

Department / Division Name	201 / Conway Street Department
-----------------------------------	--------------------------------

	Position Title	Pay Grade	Annual Salary
Proposed:	Crew Leader	32	25,680.00
Current:	Construction Specialist	12	23,361.00

"Current" information needed for reclassification only

Estimated Cost of Position:

Expenses:	
Salary Cost (when reclass, calculate the difference between current & proposed only)	2,320.00
Benefits (FICA-Medicare & Non-Uniform Pension Only)	317.00
Total	2,637.00

Salary and benefit costs are based on the costs for 19 pay periods - 1520 hours

Estimated Operating Expenses: Account Number / Name

Amount

Total Operating Expenses	-

Estimated Capital Expenses: Account Number / Name

Amount

Total Capital Expenses	-

Total Estimated Cost of New Position	
---	--

	Service Proposal
X	Reclassification

City of Conway Service Proposal & Reclassification Request

Attach your back-up to this form when submitting Service Proposals and Reclassification Requests to the Budget Office.

Department / Division Name	201 / Conway Street Department
-----------------------------------	--------------------------------

	Position Title	Pay Grade	Annual Salary
Current:	Construction Aide	1	14,659.00
Proposed:	Sign Specialist	4	18,255.00

"Current" information needed for reclassification only

Estimated Cost of Position:

Expenses:	
Salary Cost (when reclass, calculate the difference between current & proposed only)	3,596.00
Benefits (FICA-Medicare & Non-Uniform Pension Only)	491.00
Total	4,087.00

Salary and benefit costs are based on the costs for 19 pay periods - 1520 hours

Estimated Operating Expenses: Account Number / Name

Amount

Total Operating Expenses	-

Estimated Capital Expenses: Account Number / Name

Amount

Total Capital Expenses	-

Total Estimated Cost of New Position	
---	--

OB / 7A

**City of Conway
Code Enforcement
1201 Oak Street
Conway, AR 72032**



March 19, 2008

Council Members
Conway, AR 72032

Dear Council Members:

The Code Enforcement Department would like to request for re-consideration of a bid on 1470 Wildflower Street. Poor boy's Handyman Service was the lowest bidder for the cleanup on Wildflower but realized that he bided the wrong house so therefore he is asking that the city reject his bid and we would like to go with the next lowest bidder which was Paladino Construction Inc.

If you have any questions please advise.

Thank You
Barbara McElroy

Poor Boy's Handyman Service
11 Melrose Lane
Damascus, AR. 72039
Home (501) 335-7901
Cell (501) 679-1611

Conway City Hall
1201 Oak Street
Conway AR. 72032

Re: 1470 Wildflower Drive
Conway, AR 72032

To: Barbara McElroy and City of Conway,

This letter is concerning the recent bid award for 1470 Wildflower. I want to reject the bid due to the fact that I bid the wrong address. I want to apologize for any inconvenience this may of caused you.

Thank you,

Dave Richards

Dave Richards
Poor Boy's Handyman Service
Owner/Operated

2008-26 City of Conway Bid Tabulations
 Planning Development Department
 Cleanup_1470 Wildflower Street

Bidder's Name	Amount of Bid	Additional Information
Poor Boy's Handyman Service	\$4,300.00	
Paladino Construction Inc.	\$4,700.00	
Hobbs Construction	\$5,100.00	
Conway Building Services	\$5,200.00	\$500 discount if allowed to burn brush pile on site
Lipsmeyer Demolition Inc.	\$6,000.00	
K&R Services	\$18,670.00	