



CONWAY
HISTORIC DISTRICT COMMISSION
AUGUST

5:30pm • August 28, 2017 • City Hall

Robinson Historic District
&
Old Conway Design Overlay District

**CONWAY
HISTORIC DISTRICT COMMISSION
MEETING**

AUGUST 28, 2017 • 5:30PM • CITY HALL • 1201 OAK STREET

AGENDA

MINUTES
July 24, 2017

PUBLIC HEARINGS

ROBINSON HISTORIC DISTRICT
A. Porch Remodel - 835 Watkins Street

OLD CONWAY DESIGN OVERLAY DISTRICT
B. 4-Duplex Development - 1311, 1313, 1315, 1317 Bruce Street

DISCUSSION

CLG 2016 Grant Status
Scull Historic District
College Avenue Historic District NRHP Nomination
Remaining 2016 CLG Grant Funds
Eureka Springs CAMP Workshop
Realtor Education Program
2018 Historic District Commissioner Membership
Items as decided by the Commission

HISTORIC DISTRICT COMMISSION MEMBERS

Steve Hurd, Chairman
Marianne Black, Vice-Chairwoman
Scott Zielstra, Secretary
George Covington, Sr.
Taylor Martin
Betty Pickett
Gerald Tosh

HAPPY
LABOR
DAY

**Conway Historic District
Commission July 24, 2017
Meeting Minutes**

City Hall - Downstairs Conference Room, 5:30 p.m.

Roll Call
Steve Hurd, Chairman - present
Marianne Black, Vice Chairperson - present
Scott Zielstra, Secretary - present
Taylor Martin - present
George Covington, Sr. - present
Betty Pickett - present
Gerald Tosh - present
HDC City Staff - Bryan Patrick - present

Finding of a Quorum.
7 Commission members - Quorum present.

Also in attendance:
Bruce and Cindy Hendricks - Owners Hendricks Enterprises
Mike King - 2130 Hickory Street
Jason Covington - Covington Family Limited Partnership
Jason's buddy - Covington Family Limited Partnership
Shawn and Leyva Goicoechea - 2133 Hickory Street

Meeting Minutes
June 26, 2017 minutes. Taylor Martin motioned for approval, seconded by Gerald Tosh. Minutes approved unanimously.

**Hendricks Enterprises New Residences -
2135 Hickory Street**

Presentation:
Mr. Bruce Hendricks explained that he bought the property a couple years ago. Old Conway Design Overlay regulations allow the pre-1980 lot configurations to be used. This allows up to 4 residences to be constructed. After discussion with the Planning Department, the decision was made to construct 3 residences. Mr. Hendrix intends to raise the property up by about a foot so that it doesn't hold storm water. The intent is to have the water drain to the southeast corner of the property towards the drainage ditch that runs along the back. The owners would rather construct a sidewalk instead of paying the sidewalk in-lieu fee.

Neighborhood Discussion:
Mr. Goicoechea at 2133 Hickory wanted to know how the parking will work? Will the parking be in the front or the back? Parking will be in the front with a 20-21 foot depth for parking. He stated that he was glad there is a rule of no pavement over 50% of the front streetscape. How does water come out off of those buildings. Typically, gutters are not required and there is no engineering review from the city. Concern was expressed about the quantity of housing put in place but the number of units isn't a topic of

discussion for the HDC. The HDC review concerns design and neighborhood context.

Committee Discussion:
The setback is planned to be 32 from the property line. There is an additional 5 feet from property line to the curb. Design regulations state that no more than 50% of the front yard may be paved. The Commission discussed the use of single width drives or with Hollywood strips. Possibly a drive to a rear parking area. There is always a temptation, especially with rental properties, for residents to park on the grass instead of in the garage or on the street. A duplex approved by the HDC in the past used stand up curbs along the driveway to discourage yard parking. Mr. Hendricks wasn't opposed to the idea, but thought that curbs along the driveway would look non-residential.

The Commission concluded that a double driveway on east and west and a single driveway on the middle lot would be desirable. Allow a 20' wide drive on the east lot, 12' on the center lot, and 18'-9" on the west lot. The proposed houses are going to line up with the other houses on the same side of the street.

All three proposed homes and relevant conditions were discussed and included in a motion to approve:

George Covington motioned to approve the three new residences with the following conditions:

- East Residence**

 1. The residence shall be constructed as shown in submitted plans.
 2. The residence's front setback shall be approximately 32 feet from the property line.
 3. Driveway shall be concrete and 18'-9" wide and set on the eastern side of the property.
 4. Floor to ceiling height shall be 9 foot minimum.
 5. Front facade and gable siding material shall be "Smartside"
 6. Wide trim around windows and doors shall be used as shown.
 7. One over one windows shall be used in lieu of false window dividers.
 8. HVAC and utility equipment shall be appropriately located at the rear or side of the structure and/or appropriately screened.
 9. A 4 foot sidewalk shall be constructed along Hickory Street or an in-lieu fee of \$600 may be paid.

- Middle Residence**

 1. The residence shall be constructed as shown in submitted plans.
 2. The residence's front setback shall be approximately 32 feet from the property line.
 3. Driveway shall be concrete and 12 Feet wide and centered on lot.

4. Floor to ceiling height shall be 9 foot minimum.
5. Porch columns shall be a minimum of 8" x 8" when trimmed.
6. Front facade and gable siding material shall be "Smartside"
7. Wide trim around windows and doors shall be used as shown.
8. One over one windows shall be used in lieu of false window dividers.
9. HVAC and utility equipment shall be appropriately located at the rear or side of the structure and/or appropriately screened.
10. A 4 foot sidewalk shall be constructed along Hickory Street or an in-lieu fee of \$300 may be paid.

- West Residence**

 1. The residence shall be constructed as shown in submitted plans.
 2. The residence's front setback shall be approximately 32 feet from the property line.
 3. Driveway shall be concrete and 18'-9" wide.
 4. Floor to ceiling height shall be 9 foot minimum.
 5. Porch columns shall be a minimum of 8" x 8" when trimmed.
 6. Front facade and gable siding material shall be "Smartside"
 7. Wide trim around windows and doors shall be used as shown.
 8. One over one windows shall be used in lieu of false window dividers.
 9. HVAC and utility equipment shall be appropriately located at the rear or side of the structure and/or appropriately screened.
 10. A 4 foot sidewalk shall be constructed along Hickory Street or an in-lieu fee of \$600 may be paid.

Motion seconded by Taylor Martin. Marianne Black voted against approval. Motion approved 5-1.

**Covington New Mixed-Use Building -
1121/1123/1125 Front Street**

Presentation:
Mr. Patrick HDC Staff explained that the proposed structure is in the Markham street specific plan area. If applicants meet all the criteria of the plan, then staff can approve without HDC review. The structure is coming before the Commission due to the need for a variance in the amount of architectural metal siding. Staff may approve up to 30% architectural metal siding and the project has 34%. Mr. Jason Covington stated they are trying to showcase materials other than stucco. The existing building is used as a warehouse. It will become part of the new structure.

Neighborhood Discussion: N/A

Committee Discussion:
No issues with the plan as approved. Great job.

Motion made by Betty Pickett to approve the variance to allow up to 34% architectural metal on the Front Street facade:

Motion seconded by Marianne Black. Motion approved unanimously.

Discussion

Staff gave a brief update on the status of the College Avenue Historic District and Scull Historic District National Register nominations. Sandra Taylor Smith responded in an email earlier today that the College Ave District was on track for the December State Review Board. The Scull District will be reviewed by the State Board on August 2, 2017.

Adjourn
Marianne Black made the motion to adjourn. Seconded by Taylor Martin. The meeting was adjourned.

A MORGAN REMODEL - 835 WATKINS STREET

**ROBINSON HISTORIC DISTRICT
CERTIFICATE OF APPROPRIATENESS REVIEW
MORGAN REMODEL REVIEW
835 WATKINS STREET**

APPLICANT/OWNER
Matt & Ashley Morgan
2225 Wiggle Worm Road
Conway, AR 72032

SITE
Address: 835 Watkins Street

Lot Area. ± 0.31 acres

Present Zoning. R-1 (Single Family Residential). The property is within the Robinson Historic District.

Abutting Zoning. R-1 (Single Family Residential) and R-2A (Large Lot Duplex) in the Robinson Historic District.

Surrounding Area Structures. The property is located in the Robinson Historic District on the west side of Watkins Street. Area structures consist of single family residences in cottage bungalow and minimal traditional.

General Description of Property and Proposed Development. The 1920 structure is listed as non-contributing on the 1997 Robinson District Survey. The applicant is proposing to replace the front porch railings with traditional wood railing painted white with a stained handrail, add porch accent lighting, replace the front porch mailbox, house numbers, and uneven broken sidewalk. The new sidewalk will use large concrete pavers outlined with small river rock. Remove an badly trimmed overgrown large tree in the front yard.

Setbacks. Proposed setbacks should respect the predominant setbacks of area structures, especially the front setback. Front setbacks are allowed within a range of 80% to 110% of the average area front setback. The setback will remain unchanged.

Spacing. Established spacing distance pattern between area structures. Spacing will remain unchanged.

Lot Coverage. Lot coverage will remain unchanged.

Orientation. The direction in which the front of a building faces. The orientation will remain unchanged.

Alley. There are no alleys on this block.

Driveway/Parking/Carport. There is an existing gravel driveway. The driveway will remain unchanged.

Sidewalks. There is a sidewalk along Watkins at the front of the property. No sidewalk construction is required. The applicant would like to replace the broken sidewalk from the street to the porch with large concrete pavers



accented with river rock.

Fences. No fencing is proposed.

Tree preservation. There is a large silver maple the front yard. This tree has been badly trimmed by utility tree trimmers over the years. The tree is mostly "one-sided" and is very large in proportion to the size of the yard and home. Silver maples are also prone to splitting and could pose a danger to the home and homeowners. The applicant would like to remove the tree.

MASSING

Scale. The size of new construction in relation to neighboring structures and the proportion of structures to the human scale. Not applicable.

Height. The average height of area structure's eaves and cornices. Also, the first floor elevation / height relationship. Not applicable.

Width. New construction proportions shall respect the average widths of the majority of neighboring buildings in the area. Not applicable.

Directional expression. Measurement of the height to width ratio of a structure's elevation. The height/vertical expression of the residence remains unchanged.

continued on pg 6



Aerial View of 835 Watkins Street

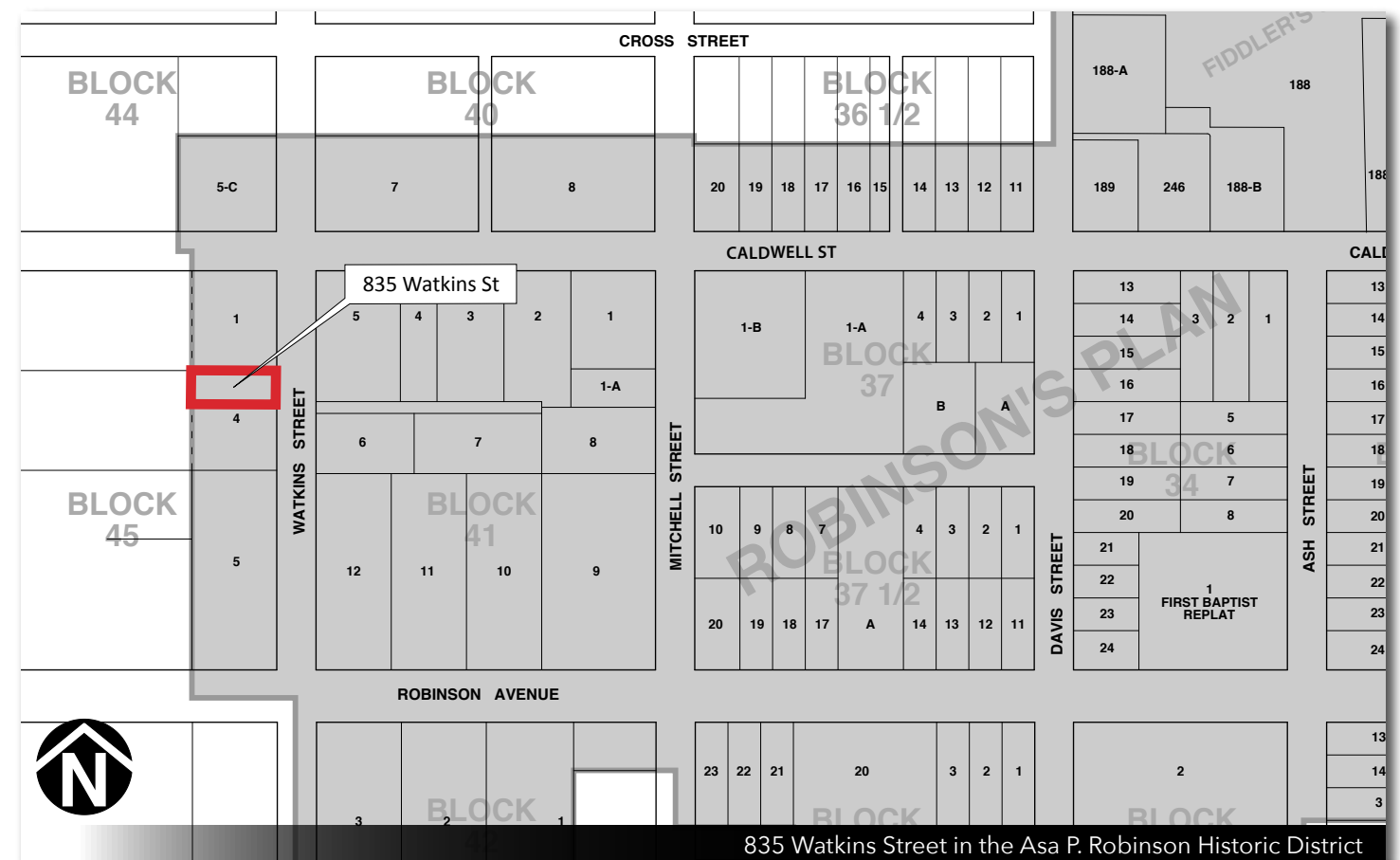

835 Watkins Street in the Asa P. Robinson Historic District

Footprint. The area of land covered by a structure should be in relation to the majority of neighboring structures. The residence’s footprint remains unchanged.

Complexity of form. The level of detailing and breaks in wall planes of a structure. The residence’s overall form remains unchanged.

Facade, wall area, rhythm. Facades shall be compatible with surrounding historic structures in proportion of wall to opening area. Not applicable.

DESIGN ELEMENTS

Style. The style should compliment the existing and area structures. The residence is listed as a “Bungalow” on the 1997 Robinson District survey.

Entries, Porches, and Porticos. Overall, the porch will not be changed.

Doors and windows. No new doors or windows are proposed. However, the rendering seems to indicate that the modern storm door will be removed.

Awnings. When new construction uses awnings, traditional awning designs, materials, and placement should be used. No awnings are proposed.

Lighting. Any new lighting should be inward, downward, and shrouded so as to stay within the bounds of the property. A new front porch light is proposed. It appears to be traditional in nature and cast light downward.

MATERIALS & DETAILING

Architectural Details, Siding, and Bricks. Eaves, brackets, dentils, cornices, moulding, columns, trim, etc. The residence is sided with modern siding. The survey indicates that it is metal siding. The applicant intends to replace the bottom 3 rows of siding as it is water damaged. The existing front porch railing is ornamental iron. Likely the railing was added in the 1960s when ornamental iron was in vogue. More traditional wooden railing is proposed. The wall mounted mail box and house numbers are also planned to be replaced.

Shutters. If used, shutters should be in proportion to their window opening. If they were closed, they should cover the window opening. Not applicable.

Roof. There is an exiting asphalt roof on the residence. No changes are planned.

Decks/Plaza Space. No decks or patio space are proposed.

Skylights. Not applicable.

Mechanical Screening. HVAC units should be visually located away from streets or screened by landscaping. Exterior HVAC ductwork should not be visible from the street. Not applicable.

General comments. The planned improvements to the front porch and yard would seem to be in keeping with the structure and area structures. The railing would offer a return to a more traditional look for the residence and would accent the front porch more favorably than narrow ornamental iron. The removal of the silver maple would seem a good long term improvement. Silver maples have a limited life span and can become hazardous. The unkind trimming has also fouled the tree.

RECOMMENDATIONS

Staff recommends approval of the planned improvements with the following conditions:

1. Porch railings shall be constructed as shown on submitted plans.
2. Lighting, mailbox, and house numbers shall be installed as shown on submitted plans.
3. The existing sidewalk may be removed and replaced with large concrete pavers and river rock as proposed.
4. The large silver maple may be removed.



Sidewalks changes

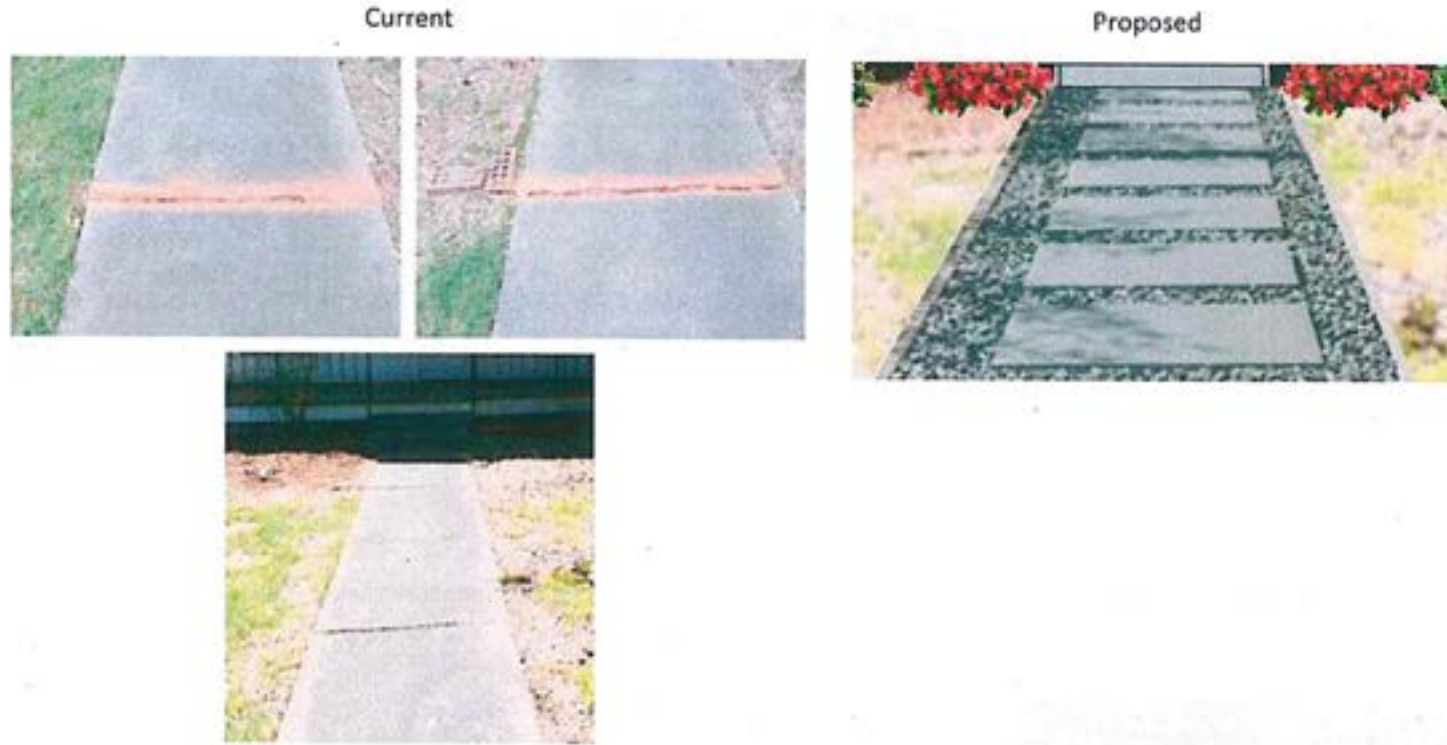

Proposed finishes & materials

Sketch of porch railing:

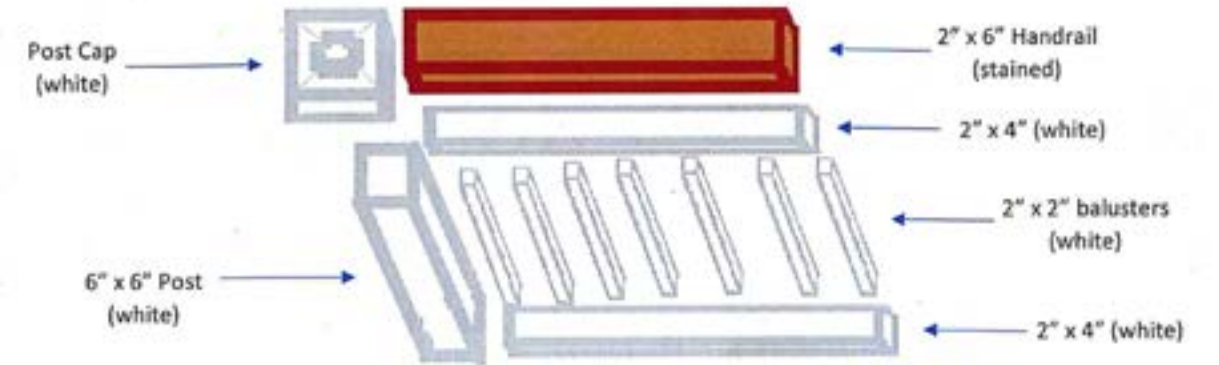

Copper wall mount mailbox:



Wall mount accent light:



Tree to be removed



Floating 5" bronze house numbers:



B BRUCE STREET APARTMENTS - 1311, 1313, 1315, 1317 BRUCE STREET

**OLD CONWAY DESIGN OVERLAY DISTRICT
CERTIFICATE OF APPROPRIATENESS REVIEW
BRUCE STREET APARTMENTS
1311, 1313, 1315, 1317 BRUCE STREET**

APPLICANT

David White - Tyler Group
240 Skyline Drive
Conway AR 72032

OWNER

Boedeker - Hamilton Properties, LLC
355 Hogan Lane Ste D
Conway AR 72034

SITE

Address. 1311, 1313, 1315, and 1317 Bruce Street

Lot Area. ± 0.76 acres

Present Zoning. R-2 (Small Lot Duplex) with a conditional use permit (1319) to allow 4 duplexes was approved on 11-27-2012. The property is within the Old Conway Design Overlay Suburban District.

Abutting Zoning. R-2 (Small Lot Duplex) in the Old Conway Design Overlay Suburban District.

Surrounding Area Structures. The property is located in the Old Conway Design Overlay Suburban District on the south side of Bruce Street. Area structures consist of a ranch duplex residence, single family ranch residences, and minimal traditional residences. Commercial metal buildings are across Bruce Street to the north including a large hardware store.

General Description of Property and Proposed Development. The applicant is proposing to construct 4 new 1049 square foot two-story duplex residences.

Setbacks. Proposed setbacks should respect the predominant setbacks of area structures, especially the front setback. Front setbacks are allowed within a range of 80% to 110% of the average area front setback. The proposed front setback is not quite applicable. The side of a duplex structure will be set at the typical 25 feet from the property line. The rear of the duplexes are set 15 feet from the west property line. The most southern duplex is set at around 28 feet from the south property line and 15 feet from the west property line. Proposed setbacks seem appropriate.

Spacing. Established spacing distance pattern between area structures. Spacing is similar to other residences and fits within the neighborhood spacing pattern.

Lot Coverage. The Old Conway District allows up to 60% impervious lot coverage. The pervious area will be well over the required 40% pervious.

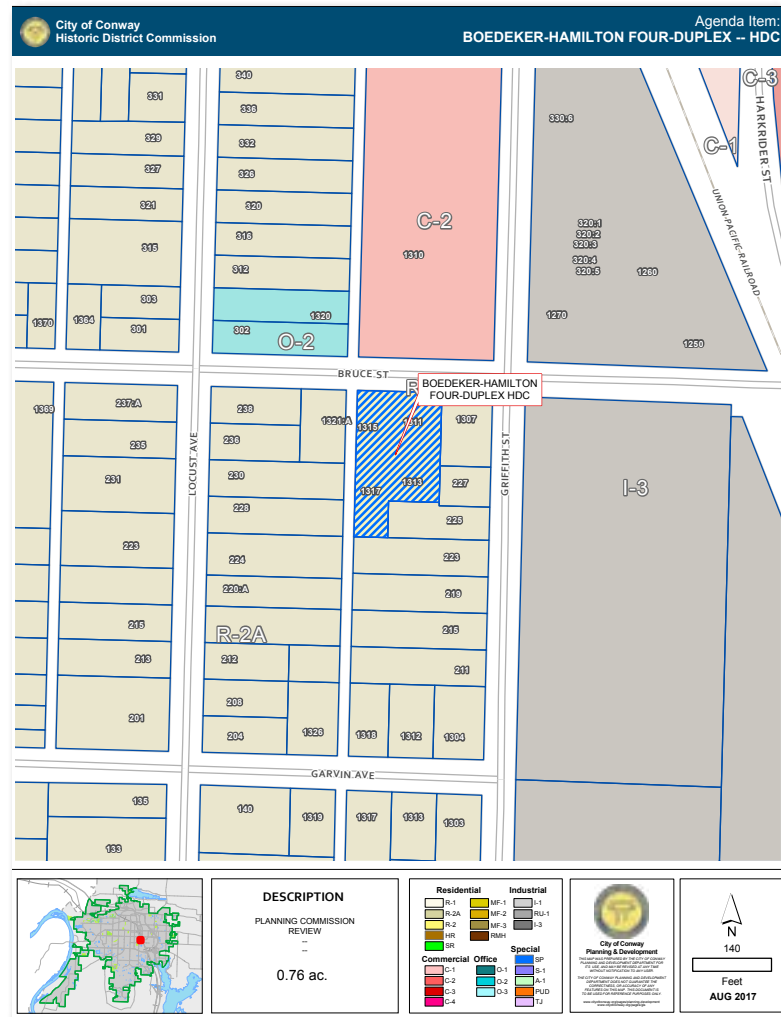

Orientation. The direction in which the front of a building faces. The duplexes face the east creating an interior orientation.

Alley. There is an unbuilt 20 foot alley abutting the west property line. This unbuilt alley is not affected by the development.

Driveway/Parking/Carport. A new driveway and parking area is planned on the east side of the property. The driveway appears to be 24 feet wide. The parking area will have 15 spaces. The city requires a minimum of 12 spaces. A dumpster is proposed at the south end of the parking area. The applicant could consider the use of roll carts instead.

Sidewalks. There are no sidewalks on the property along Bruce Street. Sidewalk construction or an in-lieu fee is required. There is around 125 feet of street frontage minus the driveway at \$12 per linear foot, requiring a sidewalk in-lieu fee of \$1500. An internal sidewalk links the duplexes to the parking area. If a sidewalk is constructed along Bruce Street, a connecting sidewalk from the internal sidewalk to Bruce should be constructed.

Fences. No fencing is shown on the submitted plans.

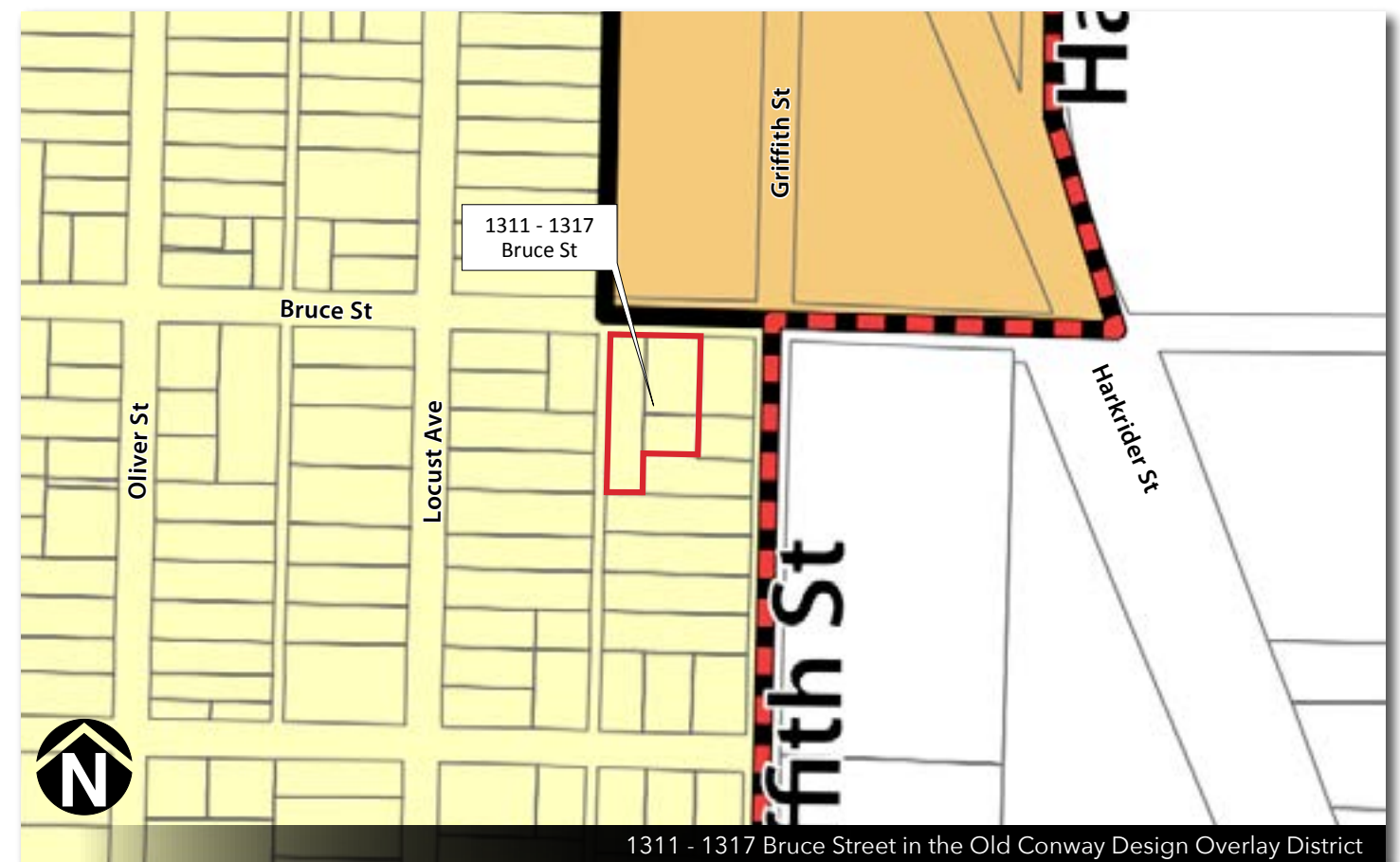

Tree preservation. No significant trees will be removed on the interior of the lot. A fence row with several significant trees exists along the east, south, and partially west property lines. These trees are likely straddling the requested property and abutting properties. Effort should be made to retain these trees as screening. A detention basin is shown along the east property line. Excavating could affect the survival of the existing fence row trees. Planning Department development review requires one tree per 30 feet along the perimeter. A deeper review could occur during development review to insure that mitigating perimeter trees are planted or fence row trees remain

MASSING

Scale. The size of new construction in relation to neighboring structures and the proportion of structures to the human scale. The new duplex's overall scale is compatible with other area residences.

Height. The average height of area structure's eaves and cornices. Also, the first floor elevation / height relationship. The overall height and eave lines are appropriate. The floor heights are noted to be 8 feet floor to ceiling. This is in keeping with area ranch style homes. The duplexes will be vertical in nature due to two story construction.

Width. New construction proportions shall respect the average widths of the majority of neighboring buildings in the area. The duplex's overall width is similar to many area homes..

Directional expression. Measurement of the height to width ratio of a structure's elevation. The duplexes are taller and more vertical than area one story homes. However, the duplexes are set back from the other homes and will blend due to distance.

Footprint. The area of land covered by a structure should be in relation to the majority of neighboring structures. The duplex footprints are appropriately scaled in relation to other area structures.

Complexity of form. The level of detailing and breaks in wall planes of a structure. The duplexes have a moderate level of detailing accomplished with shutters, varying roof line, and portico entries. The level of detailing should blend with the minimal styling of area structures.

Facade, wall area, rhythm. Facades shall be compatible with surrounding historic structures in proportion of wall to opening area. The duplexes appear to have an appropriate number of windows and doors with the exception of the second story left and right elevations. 4 additional windows should be added to the bedrooms to create a more balanced end elevation.

DESIGN ELEMENTS

Style. The style should compliment the existing and area structures. The duplex is a modern interpretation of a town home structure. This style should blend with area structures.

Entries, Porches, and Porticos. Appropriate entry points are provided. Porches are to be a minimum of 6 feet in depth. The front entry is more of a portico rather than a true porch. They are shown at 5 feet 4 inches feet in depth. As a portico, this would be an appropriate depth. Porch columns have a tapered design and appear to be appropriately scaled to the overall design.

Doors and windows. Windows are shown with one over one windows. These are more appropriate than windows with false dividers. The front door is shown as a traditional 3 panel frame and panel door.

Awnings. When new construction uses awnings, traditional awning designs, materials, and placement should be used. No awnings are proposed.

Lighting. Any new lighting should be inward, downward, and shrouded so as to stay within the bounds of the property. No lighting is shown on the plans.

MATERIALS & DETAILING

Architectural Details, Siding, and Bricks. Eaves, brackets, dentils, cornices, molding, columns, trim, etc. The duplexes are shown with brick on all 4 sides. A brick soldier course is shown under the fascia trim. A shiplap siding is shown in the portico gables. It is assumed that vinyl will be used for fascia trim and gable siding. The applicant can provide details at the meeting.

Shutters. If used, shutters should be in proportion to their window opening. If they were closed, they should cover the window opening. The proposed job-site constructed shutters appear to be appropriately sized.

Roof. An asphalt composition roof is shown.

Decks/Plaza Space. No decks or patio space are shown.
Skylights. None are shown

Mechanical Screening. HVAC units should be visually located away from streets or screened by landscaping. Exterior HVAC ductwork should not be visible from the street.

RECOMMENDATIONS

Staff recommends approval of the new residence and driveway with the following conditions:

1. The duplexes and driveway shall be constructed as shown in submitted plans.
2. Fence row trees shall be preserved as much as possible. Trees and landscaping shall be reviewed in depth as part of Planning Staff development review.
3. Four additional windows shall be placed on the left and right elevations as shown in Staff sketch.
4. Siding material?
5. HVAC and utility equipment shall be appropriately located at the rear or side of the structure and/or appropriately screened.
6. A 5 foot sidewalk shall be constructed along Bruce Street with an interior sidewalk connection to the new Bruce Street sidewalk.

Site Plane including Staff changes

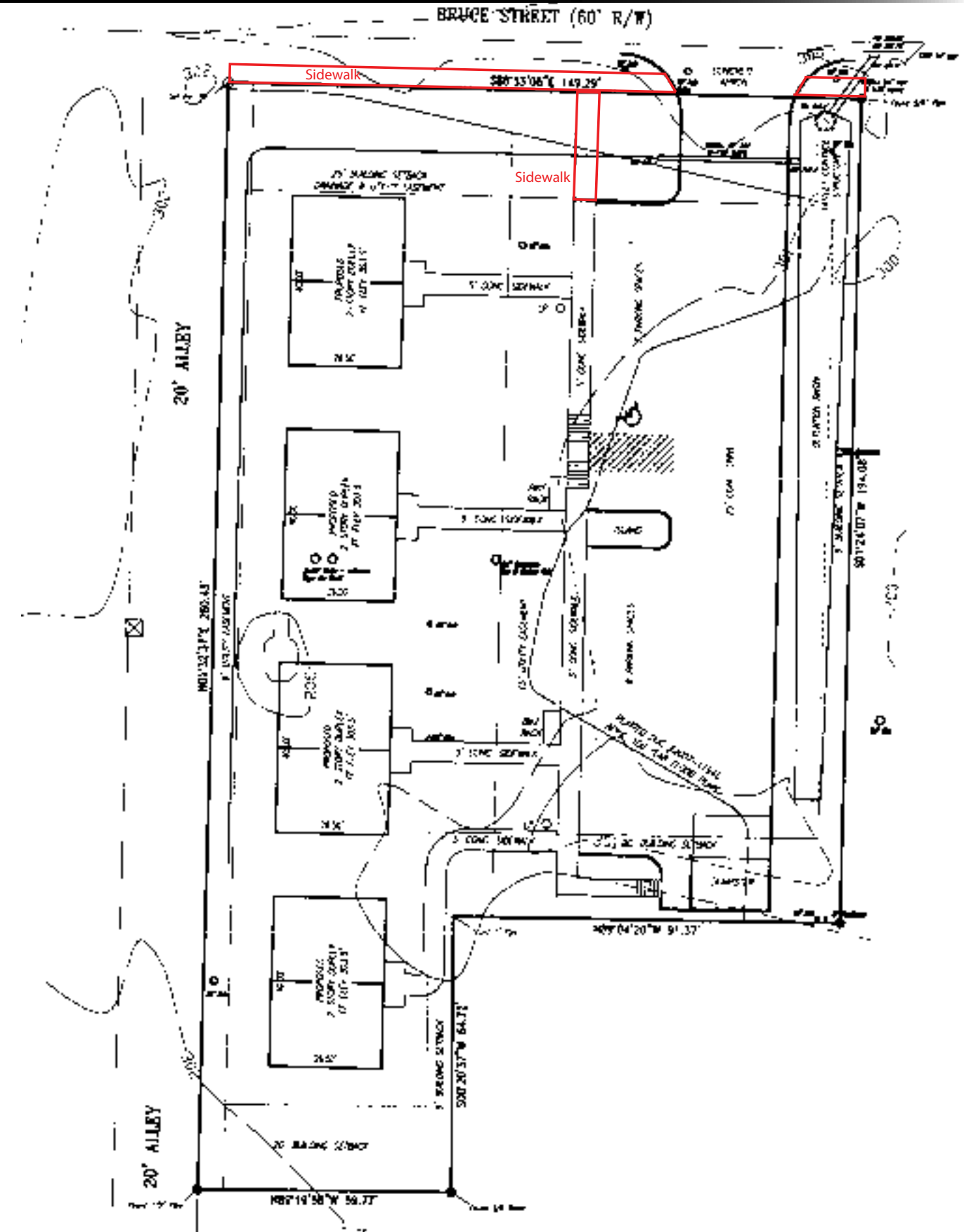

Floor Plan & Elevations including Staff changes

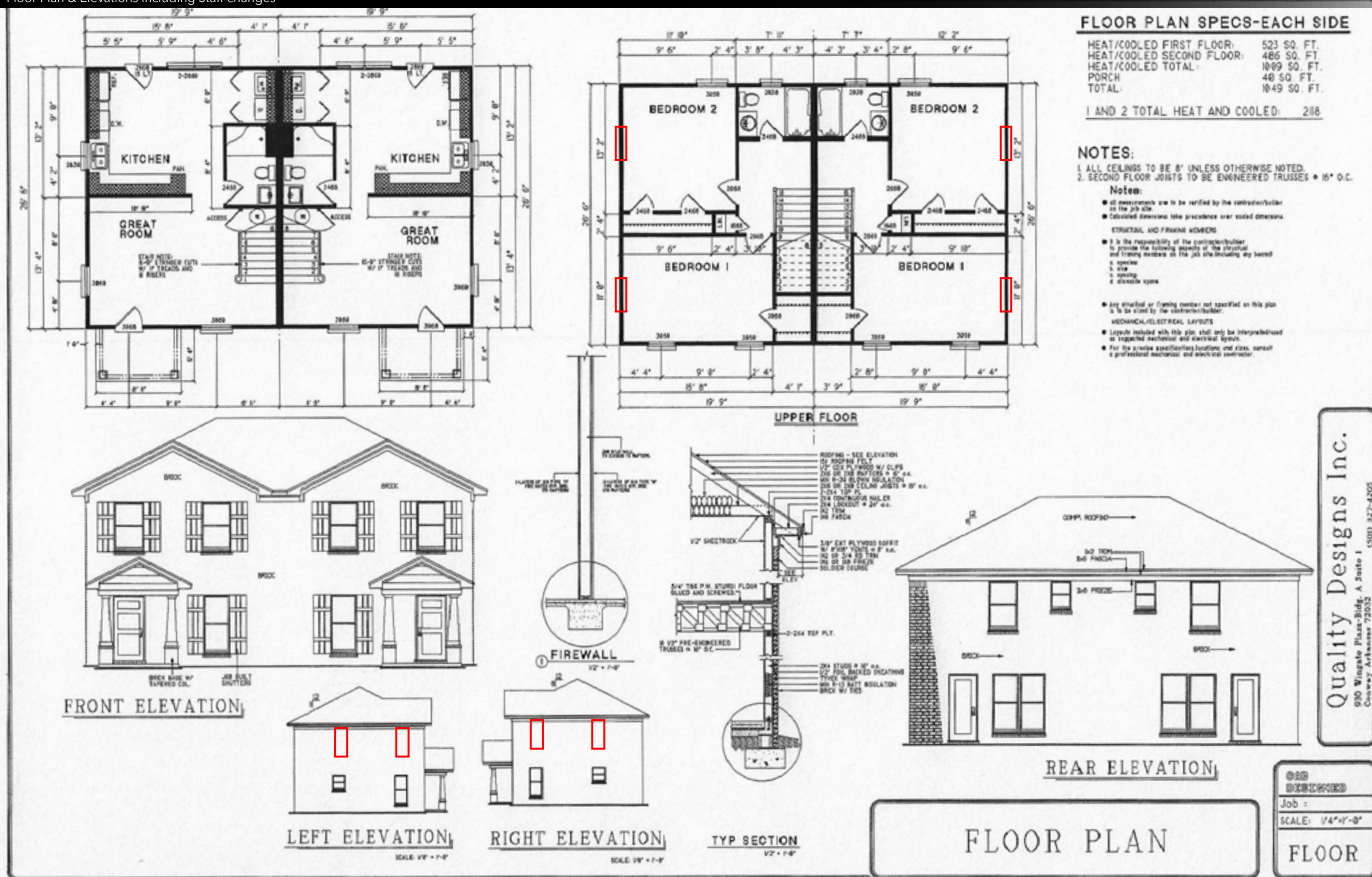

CLG 2016 Grant Status - Faulkner County Museum

The Arkansas Historic Preservation Program has approved the Faulkner County Museum drainage study project is complete. The \$3500 engineering fee has been paid.

Scull Historic District

2 Residence Handmade Concrete Block Historic District - 428 and 432 Conway Boulevard

The Arkansas State Review Board has reviewed and recommended approval of the Scull Historic District National Register nomination to the National Park Service.

College Avenue Historic District NRHP Nomination

Sandra Taylor Smith is planning to submit the College Avenue Historic District National Register of Historic Places Nomination in September 2017. If submitted in time, the nomination will be reviewed by the State Review Board in December 2017. If she cannot submit in September, the nomination will be submitted in January 2018 and reviewed in April 2018.

Remaining 2016 CLG Grant Funds

There is \$1300 remaining in the 2016 CLG grant. There are a couple of opportunities to decrease this amount:

Eureka Springs CAMP Workshop. A Commissioner Assistance and Mentoring training session will be offered on September 18, 2017. Topics covered will include design guidelines and the Secretary of the Interior's Standards, reading plans, design review nuts-and-bolts, approaches to infill design, and issues related to alternative materials. More information about trainers and materials will be emailed asap.

- **LODGING** - If you plan to stay overnight in Eureka Springs the night before CAMP, Glenna Booth with the City of Eureka Springs is planning a small welcome get-together and tour of the lovely 1929 City Auditorium, which was rehabilitated with the help of a Save America's Treasures grant, on the evening of Sunday the 17th. The Basin Park Hotel will be giving attendees the state rate of \$89 per night if you tell them you are attending the state historic preservation training. Doug Breitling, owner of the Arsenic and Old Lace B&B and a former Eureka Springs HDC commissioner, has offered to give discounted rates to attendees.
- **REGISTRATION** - CAMP Eureka Springs registration: <https://goo.gl/forms/9L1ul557mzzK07073>

Realtor Education Program

AHPP Staff has given preliminary approval of a realtor training or similar activity. If a realtor workshop is to be held, we'll need to move quickly in order to spend the money no later than September 30 and invoice to AHPP no later than Oct 15.

2018 Historic District Commissioner Membership

Scott Zielstra, Taylor Martin, and Betty Pickett roll off the Historic District Commission on December 31, 2017. Scott and Betty will be at the end of their allowed terms. City ordinances establish that members of the Historic District Commission are allowed 2 terms only. Scott and Betty are currently serving their second terms. Betty is also serving as the Pine Street Community Development Corporation Member. Taylor may request an additional term expiring in December 2020. If Taylor reenlists, the Commission will need 2 new members for 2018 one of which represents the Pine Street Community Development Corporation. Nominations for City boards and commissions are accepted during the month of October.